

LIVING IN LUXEMBOURG 1

This booklet belongs to

Full name

Class



Unit	Topic	Page		
I.	Luxembourg trivia	Quiz – how much do you know about Luxembourg?	4	
		Fact or fake – what do you think?	8	
II.	Mobility	1. Parts of Luxembourg – directions and orientation	9	
		2. Finding your way around Luxembourg - maps, coordinates and scales	11	
		3. Finding your way around Luxembourg – city maps/plans and road grids	13	
		4. Free public transport	19	
III.	Places worth visiting	1. Ansembourg	23	
		2. Berdorf	24	
		3. Bettembourg	25	
		<i>This is a random list, which is not meant to be exhaustive. The selection is based on the language learning potential of the materials.</i>	4. Diekirch and Ettelbrück	29
		5. Grevenmacher	31	
		6. Munshausen	35	
		7. Rosport	36	
IV.	Traditions and events	1. 13 typical Luxembourgish traditions	40	
		2. ‘Allerhellegen’ and ‘Trauliicht’	43	
		3. ‘Bazar International’	45	
		4. ‘Neklosdag’	52	
		5. ‘Liichtmëssdag’	56	
		6. ‘Buerghsonndeg’	58	
		7. ‘Bretzelsonndeg’	60	
		8. ‘Klibberen’	61	
		9. ‘Émaischen’	63	
		10. ‘Meekranz’	65	
		11. ‘Oktav’	66	
		12. ‘Sprangprëssessioun’	68	
		13. ‘Nationalfeierdag’	70	
		14. Summer in the City	72	
		15. ‘Schueberfouer’	73	
		16. ‘Kirmes’	75	

I. Luxembourg trivia

1. Quiz – how much do you know about Luxembourg?

1. When was Luxembourg founded?
 - a. 963
 - b. 1815
 - c. 1839
 - d. 1890
2. What is Luxembourg in political terms?
 - a. a grand duchy
 - b. a kingdom
 - c. a principality
 - d. a republic
3. Which of the following countries does **NOT** have a border with Luxembourg?
 - a. Belgium
 - b. Germany
 - c. France
 - d. the Netherlands
4. What was the total population of Luxembourg in 2022?
 - a. 384.400
 - b. 439.500
 - c. 645.400
 - d. 749.200
5. How many children did a woman give birth to in 2021 on average?
 - a. 1 child
 - b. 1.38 children
 - c. 2.5 children
 - d. 3 children



6. In 1970 Luxembourgers made up 81% of the population. What proportion of residents were Luxembourgish in 2022?
- a. 70.6%
 - b. 63.1%
 - c. 53.9%
 - d. 49.8
7. What proportion of Luxembourg's workforce were cross-border commuters in 2021?
- a. 25%
 - b. 33%
 - c. 43%
 - d. 48%
8. What is / are the administrative language(s) of Luxembourg?
- a. Luxembourgish
 - b. French
 - c. Luxembourgish and French
 - d. Luxembourgish, French and German
9. What is depicted on the Luxembourg coat of arms?
- a. a bear and a wolf
 - b. an eagle
 - c. a red lion
 - d. a shield and a sword
10. What Luxembourgish politician served as the 21st Prime Minister of Luxembourg, and as the 12th President of the European Commission?
- a. Xavier Bettel
 - b. Jean-Claude Juncker
 - c. Gaston Thorn
 - d. Pierre Werner

11. People refer to national day as the birthday of Grand Duke Henri. When is his real birthday?

- a. 16 April
- b. 1 August
- c. 2 November
- d. 13 December

12. When did Luxembourg become a member of the EU (formerly EEC)?

- a. 1945
- b. 1949
- c. 1957
- d. 1999

13. How many European Union institutions are located or have offices in Luxembourg?

- a. 3
- b. 5
- c. 10
- d. 13

14. How many times has Luxembourg City been named the European Capital of Culture?

- a. not even once
- b. once
- c. twice
- d. three times

15. In what year did Luxembourg legalize same-sex marriage?

- a. 2002
- b. 2011
- c. 2015
- d. 2020



16. Luxembourg recently released its own branded emojis, called EmoXies. What was **NOT** a featured Emoxie?
- a. Gromperekichelcher
 - b. the Golden Lady
 - c. the Moselle
 - d. a satellite
17. How many UNESCO-recognized cultural sites are located in Luxembourg?
- a. 1
 - b. 2
 - c. 3
 - d. 4
18. What telecommunications company and subsidiary of Microsoft has their European headquarters in Luxembourg?
- a. Orange
 - b. Skype
 - c. Tango
 - d. Vodaphone
19. What is the meaning of 'Mir wëlle bleiwe wat mir sinn'?
- a. we want to be famous.
 - b. we want to be the best
 - c. we want to be wealthy
 - d. we want to stay what we are
20. What is the meaning of 'Wann ech gelift'?
- a. goodbye
 - b. please
 - c. sorry
 - d. thanks

For more figures on Luxembourg, go to

[luxembourg-figures \(2\).pdf](#)

[file:///C:/Users/romai/Downloads/luxembourg-figures%20\(2\).pdf](file:///C:/Users/romai/Downloads/luxembourg-figures%20(2).pdf)

2. Fact or fake– what do you think?

		Fact	Fake
1.	Luxembourg is the only Grand Duchy in the world.	<input type="checkbox"/>	<input type="checkbox"/>
2.	Luxembourg is the richest country in the world	<input type="checkbox"/>	<input type="checkbox"/>
3.	Luxembourg offers Europe's highest minimum legal salary.	<input type="checkbox"/>	<input type="checkbox"/>
4.	Luxembourg is the smallest country of Europe.	<input type="checkbox"/>	<input type="checkbox"/>
5.	The national religion of Luxembourg is a Roman Catholicism.	<input type="checkbox"/>	<input type="checkbox"/>
6.	People of more than 170 different nationalities coexist in Luxembourg.	<input type="checkbox"/>	<input type="checkbox"/>
7.	There are 30 km of underground tunnels cut out of the solid rock beneath Luxembourg City.	<input type="checkbox"/>	<input type="checkbox"/>
8.	Echternach is the oldest city in Luxembourg.	<input type="checkbox"/>	<input type="checkbox"/>
9.	More than a third of the country is covered by forests.	<input type="checkbox"/>	<input type="checkbox"/>
10.	The Schengen Agreements, which allow Europeans to travel freely across European borders, were signed in Luxembourg	<input type="checkbox"/>	<input type="checkbox"/>
11.	The highest court in the EU in matters of EU law is located in Luxembourg.	<input type="checkbox"/>	<input type="checkbox"/>
12.	Luxembourg has the fifth highest level of tertiary education in the EU.	<input type="checkbox"/>	<input type="checkbox"/>
13.	The University of Luxembourg ranks among the 201-250 best universities in the Times Higher Education (THE) World University Ranking 2023.	<input type="checkbox"/>	<input type="checkbox"/>
14.	Euthanasia and assisted suicide are legal in Luxembourg.	<input type="checkbox"/>	<input type="checkbox"/>
15.	Luxembourg is the first country in Europe to legalise the production and the consumption of cannabis for adults.	<input type="checkbox"/>	<input type="checkbox"/>
16.	Luxembourg has the highest rate of car ownership in the world.	<input type="checkbox"/>	<input type="checkbox"/>
17.	In 2022 BMW was the top-selling car brand in Luxembourg.	<input type="checkbox"/>	<input type="checkbox"/>
18.	Meluxina, Luxembourg's new supercomputer, has a calculating power of 10 petaflops (= a million billion or 10^{16} operations per second).	<input type="checkbox"/>	<input type="checkbox"/>
19.	The Luxembourg-based satellite telecommunications network provider SES owns over 70 satellites, which can reach almost the entire world population.	<input type="checkbox"/>	<input type="checkbox"/>
20.	The Grand Duchy is the first country worldwide to offer a legal framework on the exploration and use of space resources, ensuring that private operators can be confident about their rights on resources they extract in space.	<input type="checkbox"/>	<input type="checkbox"/>
21.	Luxembourg's RTL Group (Radio Télévision Luxembourg) is Europe's largest TV, radio and production company.	<input type="checkbox"/>	<input type="checkbox"/>
22.	The restaurant Chiggeri is know for having the world's largest wine list.	<input type="checkbox"/>	<input type="checkbox"/>
23.	Fränk Schleck won the 'Tour de France' in 2010.	<input type="checkbox"/>	<input type="checkbox"/>
24.	Luxembourg won the Eurovision Song Contest twice.	<input type="checkbox"/>	<input type="checkbox"/>

II. MOBILITY

1. Parts of the country, directions and orientation

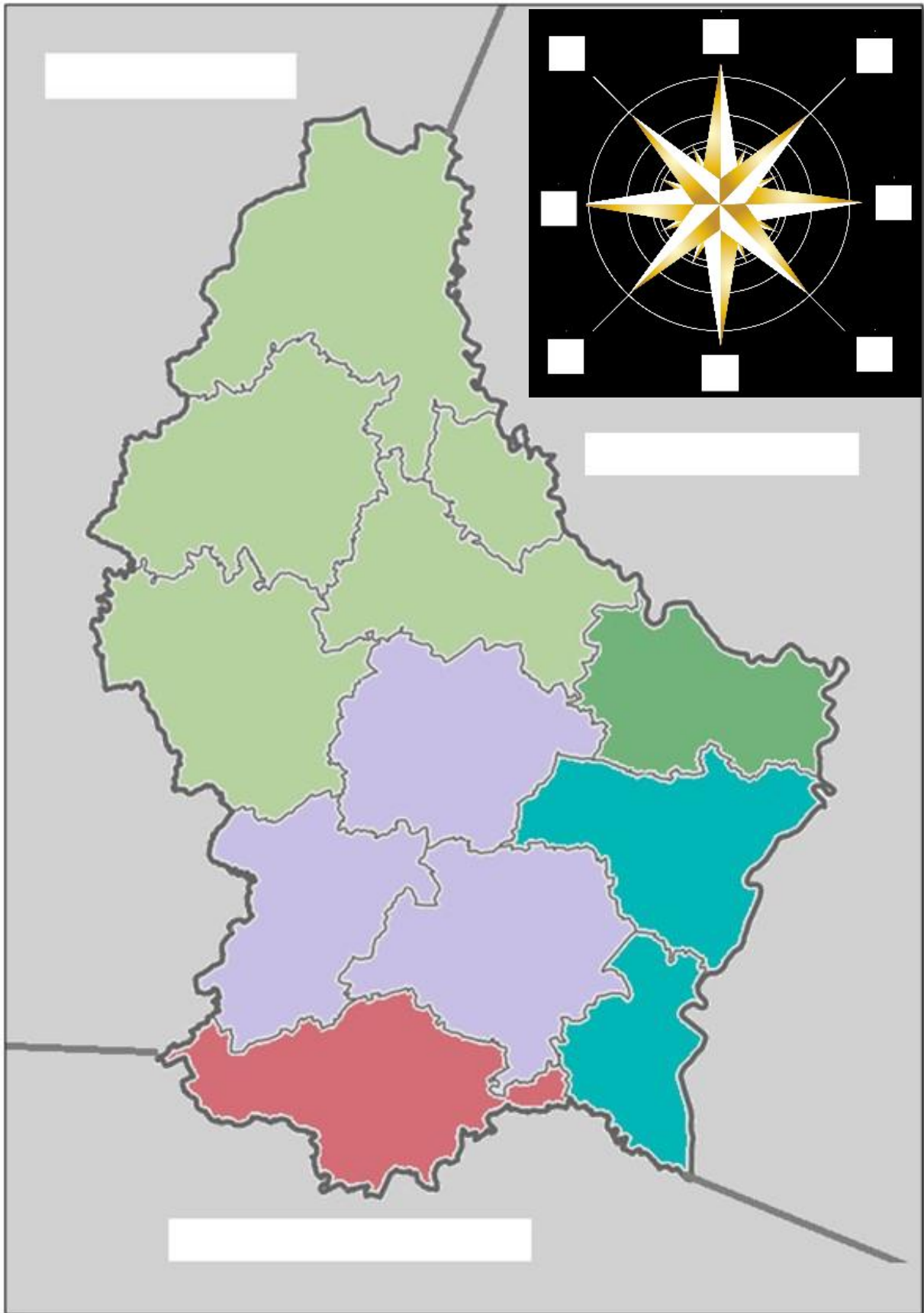

Luxembourg is basically subdivided in the Ardennes and the Guttland:

- the light green area is the Ardennes; the Ardennes consist of high plateaux and deep valleys.
- the rest of the country is the Guttland; the landscape of the Guttland is often described as 'rolling' as it consists of gentle hills and wide valleys.

The Guttland is further subdivided into a number of sub-regions:

- the dark green area is the Müllerthal;
- the turquoise area is the Moselle;
- the red area is the land of the red rocks.

What do you know about the different regions of Luxembourg?

Why do you think that the South of Luxembourg is called the land of the red rocks?

Ask your teacher questions to find out more?

The figure in the top right corner is a compass rose or wind rose. It shows the orientation of the cardinal directions (north, east, south and west) and their intermediate points (northeast, southeast, southwest and northwest).

Label the compass rose. Fill in

N for North

S for South

NE for North-East

SE for South-East

E for East

W for West

NW for North-West

SW for South-West

The dark grey lines represent the borders of Luxembourg and its neighbouring countries.

Identify the three neighbouring countries of Luxembourg and write down their names in the white boxes.

In the West, there is _____.

In the _____, there is _____.

In the _____, there is _____.

What does the border between Luxembourg and Germany consist of?

land

mountains;

rivers.

What is it / are they called?

Which other Luxembourg rivers do you know?

2. Finding your way around Luxembourg: maps, coordinates and scales

Latitude and longitude are a system of lines used to describe the location of any place on Earth. Although these are only imaginary lines, they appear on maps and globes as if they actually existed.

Lines of latitude (also called parallels) run in an east-west direction across Earth. They circle the Earth parallel to the Equator. Lines of latitude describe positions north and south of the Equator. The Equator is 0°. The North Pole is 90° north (N), and the South Pole is 90° south (S).

Lines of longitude run between the North Pole and the South Pole. These lines are also called meridians. The north-south line that marks 0° longitude passes through Greenwich, England. This is called the Greenwich, or prime, meridian. Greenwich was chosen for the prime meridian because when the system of latitude and longitude was established Great Britain was a world leader in exploration and map making.

Both lines of latitude and lines of longitude are measured in degrees, minutes, and seconds.

Latitude and longitude together can describe the exact location of any place on Earth.

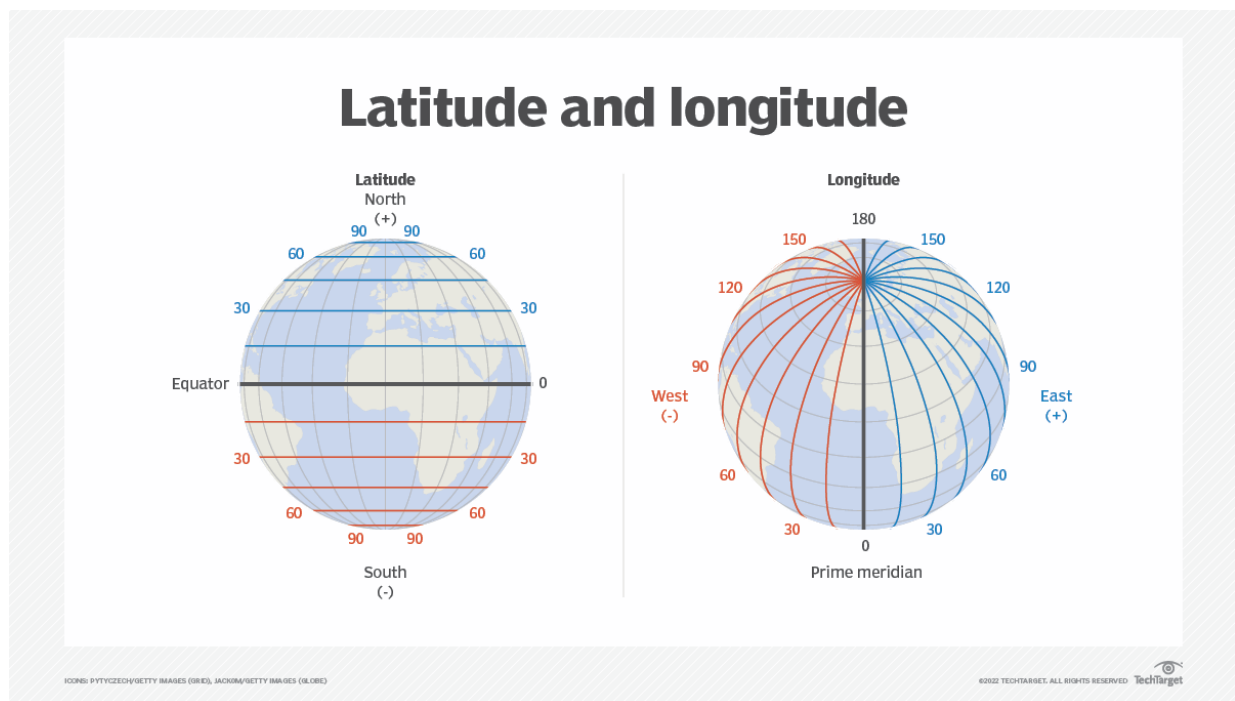

Coordinates play an important role with relation to the global positioning system (GPS).

GPS is a network of 24 satellites that circle the Earth in precise orbits as well as receiving devices used to determine the location of something on Earth. Some GPS receivers are so accurate they can establish their location within one centimetre (0.4 inches). GPS receivers provide location in latitude, longitude, and altitude. They also provide the accurate time. Each satellite makes a full orbit of the Earth every 12 hours. These satellites are constantly sending out radio signals.

GPS receivers are programmed to receive information about where each satellite is at any given moment. A GPS receiver determines its own location by measuring the time it takes for a signal to arrive at its location from at least four satellites. Because radio waves travel at a constant speed, the receiver can use the time measurements to calculate its distance from each satellite.

Luxembourg City, for instance, lies about 49 degrees 36 minutes 42 seconds north of the Equator and 6 degrees 7 minutes 48 seconds east of the prime meridian. These two numbers together are called coordinates.

Esch-sur-Alzette lies about 49 degrees 29 minutes 45 seconds north and 5 degrees 58 minutes 50 seconds east.



Which latitude line does Mersch lie on? _____

Which latitude line does Mondorf-les-Bains lie on? _____

Which meridian does Troisvierges lie on? _____

Which meridian does Junglinster lie on? _____

As maps and plans cannot be the same size as the area they represent, they need to be scaled down to fit on a page or a screen. The map scale is therefore an important piece of information on a map.

What is the scale of the above map? _____

Find out the coordinates of your hometown or village using

<https://www.geodatos.net/en/coordinates/luxembourg>

If you want to play a free short online game using coordinates, go to

<https://www.geoguessr.com/vgp/3252>

3. Finding your way around Luxembourg – city maps/plans and road grids

City maps often use a different kind of grid, namely a road grid.

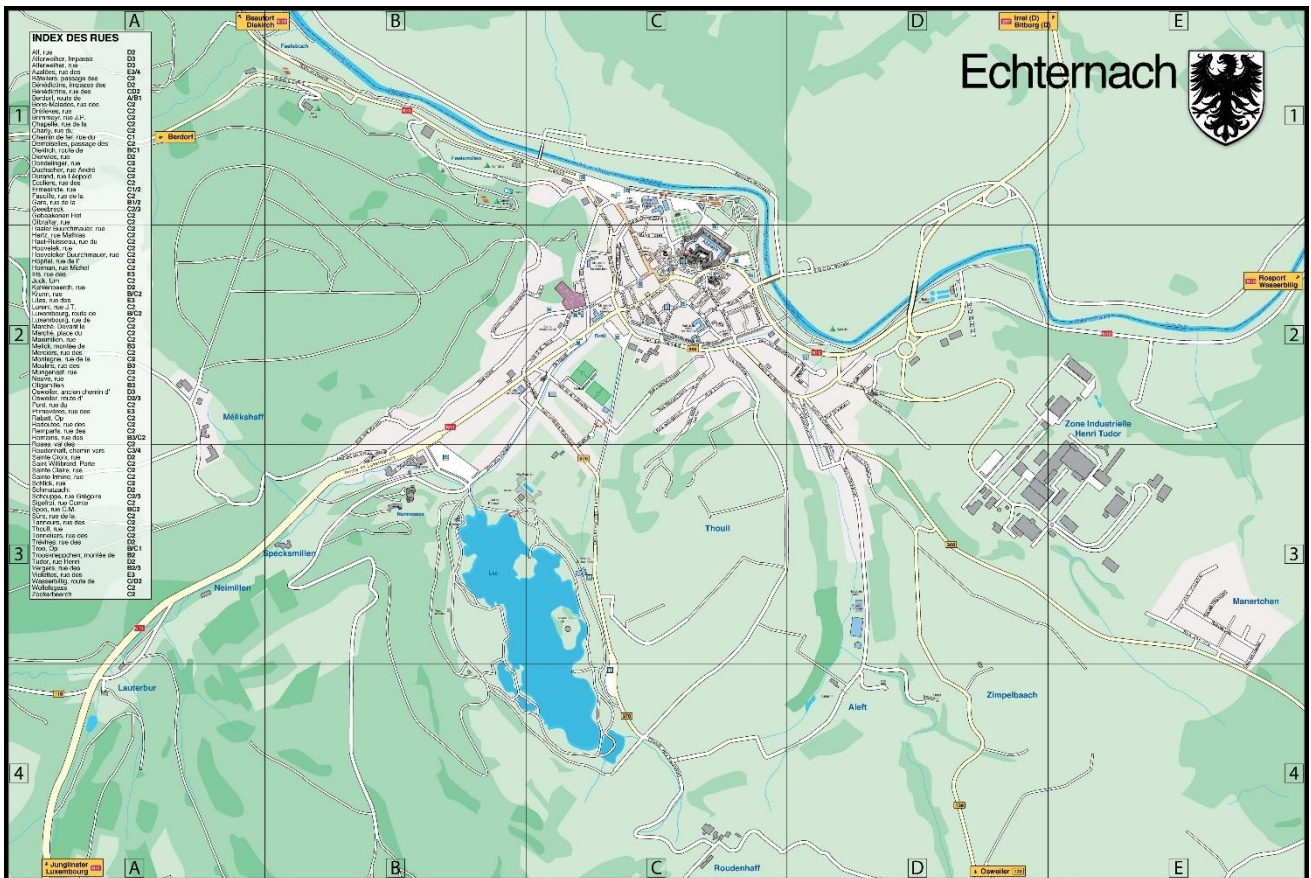

When taking a road grid reference, you must always read left to right along the bottom or top of the map first and then top to bottom or bottom to top along the side of the map.

Maps do not only provide information on directions and distances. Apart from the different roads of Echternach, the above map also represents specific buildings such as the Abbaye, an industrial park, sports grounds, a lake, the border between Luxembourg and Germany etc.

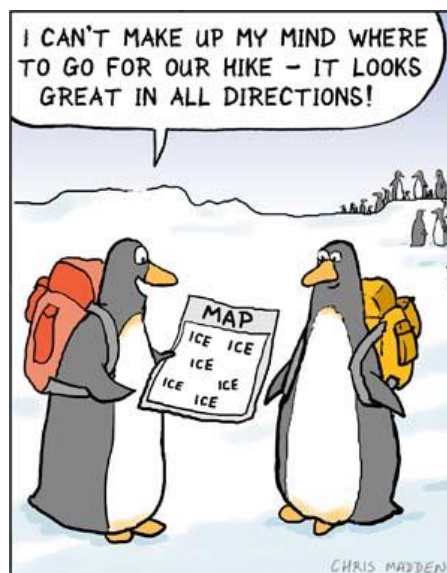

4. Finding your way around Luxembourg: maps, keys or legends

Some maps use symbols to describe certain details. A list which is known as the map key or legend offers explanations for the symbols.



The map below uses a lot of symbols. It can be found in a leaflet called 'Hits for kids' by the Müllerthal Tourism Board. The map gives you a clear overview of different low-cost or free activities which can be undertaken in the region that is represented. These activities are of particular interest to children and teenagers, but they are also pleasurable for the families and older people.

Compare the above map with the maps on pages 14 and 16 to find out which region is being represented.

Name of the region _____.



Describe where the region is located.

This region is also known as 'Luxembourg's little Switzerland'. What is Switzerland associated with?

What does this nickname suggest?

Sometimes the symbols are self-evident, i.e. you understand what they represent by merely looking at them. This is, for example, the case of the following pictures (symbols). Say what activities the pictures below represent.







Other pictures on the map simply represent local buildings or landmarks.

What kind of buildings or landmarks do the following pictures represent?

Ask your teacher questions to find out more.





The first picture represents a kind of building that is frequent in Luxembourg.

Find three other places on the map where there are similar buildings.

'Müllerthal'

Before you read the text on the 'Müllerthal' that comes with the map, match the words from the text (1-18) with the definitions (a-u). There is an example (0,o)

- | | |
|------------------|--|
| 0. ascent | a. the ability to keep doing something difficult, unpleasant or painful for a long time |
| 1. balance | o. the act of climbing or moving up |
| 2. cave | b. completely dark |
| 3. canal | c. (to) give something to somebody or make it available for them to use |
| 4. (to) crawl | d. the hard solid material that forms part of the surface of the earth and some other planets |
| 5. crevice | e. a large hole in the side of a hill, cliff, mountain or under the ground |
| 6. endurance | f. a long, thin stretch of water that is artificially made either for boats to travel along or for taking water from one area to another |
| 7. faint-hearted | g. a long walk in the country |
| 8. flashlight | h. to move along on hands and knees or with your body stretched out along a surface |
| 9. helmet | i. not being confident or brave enough |
| 10. hike | j. a place where a road or river curves rather than being in a straight line |
| 11. meander | k. real and not imaginary; able to be shown, touched or experienced |
| 12. medieval | l. related to the Middle Ages (about AD 600 to AD 1500) |
| 13. path | m. right or appropriate for a particular purpose or occasion |
| 14. pitch-dark | n. rough path |
| 15. (to) provide | p. a route or track between one place and another, or the direction in which something is moving |
| 16. rock | q. a small electric lamp that you can hold in your hand and carry with you |
| 17. suitable | r. a small, narrow crack or space, especially in the surface of rock |
| 18. tangible | s. a state where things are of equal weight or force |
| 19. track | t. a type of hard hat that protects the head, worn for example, by a soldier or a person riding a bike or motorbike |
| 20. (to) wind | u. to twist yourself to be able to move forward |

Write your
answers
here

0	1	2	3	4	5	6	7	8	9	10	11	12	13	14	15	16	17	18	19	20
o																				

Hiking is tedious?!?

The **Kuelscheier** cave near Consdorf is not suitable for the faint-hearted among you: you will wind through the 100 m long crevice in the sandstone rock formations of Adventure Kuelscheier. Don't forget to take your flashlight as your way through it is partially pitch-dark. You will start your hike at the parking lot of Konsdrefer Millen and make a round trip of +/- 3 km.

Raiberhiehl (The Thieves' Den) is situated on the local path B2 in Berdorf (4.2 km). In the beginning, you almost crawl and at the end, you climb up a ladder to get out of the cave.

The "**Kimmfräichen**" or "White Lady" shows the way on the meander of the Sûre in Rosport (hiking path R7 3,5 km). If the weather is hot, you may see lizards on the dry-stone walls. Also plan enough time to explore the adventure playground in Rosport where you start and finish your hike.

You may ascent to the remains of the **Heringer Buerg** situated on the local path W2 - the hike has a total of 3,6 km - in the village of Mullerthal. You start your hike at the Touristcenter Heringer Millen.

Those who do not want to hike that much should test their balance skills on the **Motorik-Park** and the 800 m long **barefoot path** near Camping Kengert in Medernach. "Joffer Margot" in Consdorf, "Naturpad" in Beaufort, "In the footsteps of Charlie" in Bech, "Beieléierpad" in Waldbillig, "Deiwelskopp" in Mompach and "Wanterbaach-Sieweschléff" in Berdorf are the names of **thematic footpaths** for children in the region.

Bad weather solutions

If you want to climb up the **indoor climbing wall** in the youth hostel in Echternach, you should be at least 10 years old and you need to register in advance. There are beautiful **indoor playgrounds** on Camping Kengert in Medernach and at the youth hostel in Beaufort. In Beaufort, you can even go **bowling**.

You might feel like doing some exciting experiments with electricity? Then go to the **Musée Tudor** in Rosport! If you like interactive games about water and geology, climb up the **Aquatower** in Berdorf! Your parents will enjoy the panoramic view on the surroundings of Berdorf, on a height of more than 50 m.

You think that culture and history are boring...

...unless you visit the **castles** of Beaufort, Larochette and Bourglinster where medieval life becomes tangible. The torture room of Beaufort Castle is a bit scary if you imagine that these torture instruments were really in use in former times.

A less frightening place is the Didactic Museum of the Romans in the **Roman Villa** at Echternach lake. Lifelike figures show what the Romans' life was like in a kitchen or in a classroom. After the visit, you can spend time on the big playground just opposite to the museum.

And action!

If you want to jump real high: the youth hostel in Echternach provides you with **trampolines** and **Bungee trampolines**, only available though during season, between Easter and September. You can explore the river Sûre by **kayak** from Wallendorf to Echternach! The **playgrounds** in Nommern, Berdorf, Rosport and at the lake of Echternach provide you with adventurous facilities.

Touristcenter Heringer Millen in Mullerthal organizes, after prior arrangement **baking workshops**, **pirate treasure hunts** and **duck fishing** on the small canal. The small picturesque waterfall called **Schiessentümpel** is nearby and you can reach it by foot after 15 minutes. During summer, you can refresh yourself in the icy water. During summer, the numerous **outdoor pools** in the region are also quite re- freshing and in winter, you will have fun on the **ice skating rink** in Beaufort.

By bike

You don't have your own bike with you? No problem: you can rent one as well as a helmet and all the necessary accessories at **Rentabike Möllerdall**. And the best: you can take your bike in one of the 14 stations in the region and hand it back in any other station.

On the **mountain bike track Becher Minibike** in Bech and on the **bike parks** in Berdorf and Echternach, you can test your endurance and your cycle skills.

Comprehension

Help the following people to choose an activity. Tick ✓ the best option (a, b or c), and explain your choice.

- Jim often decides spontaneously to go for a hike, so he rarely has special equipment with him. He loves challenges and he is really fit. Which of the following hikes would be best for him?
 - a. the 'Kimmfrächen'
 - b. the 'Kuelscheier' cave
 - c. the 'Raiberhiel'

- It is raining heavily and Ann wants to take friends with young children on a trip. Where should she take them?
 - a. the adventure playground in Rosport
 - b. camping Kengert
 - c. the Roman Villa in Echternach

- Mary loves Greek and Roman history.
 - a. Beaufort castle
 - b. Heringer Bueg
 - c. the didactic museum at Echternach lake

- Pete's bike is being repaired. Where can he get help with his problem, if he wants to go on a long biking tour?
 - a. Becher Minibike
 - b. the bike park in Berdorf
 - c. Rentabike Mëllerdall

Lexis

Find the odd one out. There is an example (0).

					Explanation
0.	abbey	basilica	church	<u>museum</u>	<i>not related to religion</i>
1.	bottom	north	right	top	_____
2.	border	grid	latitude line	longitude line	_____
3.	bowling	ice-ring	pool	skater park	_____
4.	castle	manor	rock	skyscraper	_____
5.	city	ruin	town	village	_____
6.	compass rose	legend	map	scale	_____
7.	east	left	south	west	_____
8.	field	forest	playground	wood	_____
9.	hill	mountain	plateau	village	_____
10.	pool	river	stream	waterfall	_____

4. Free public transport¹

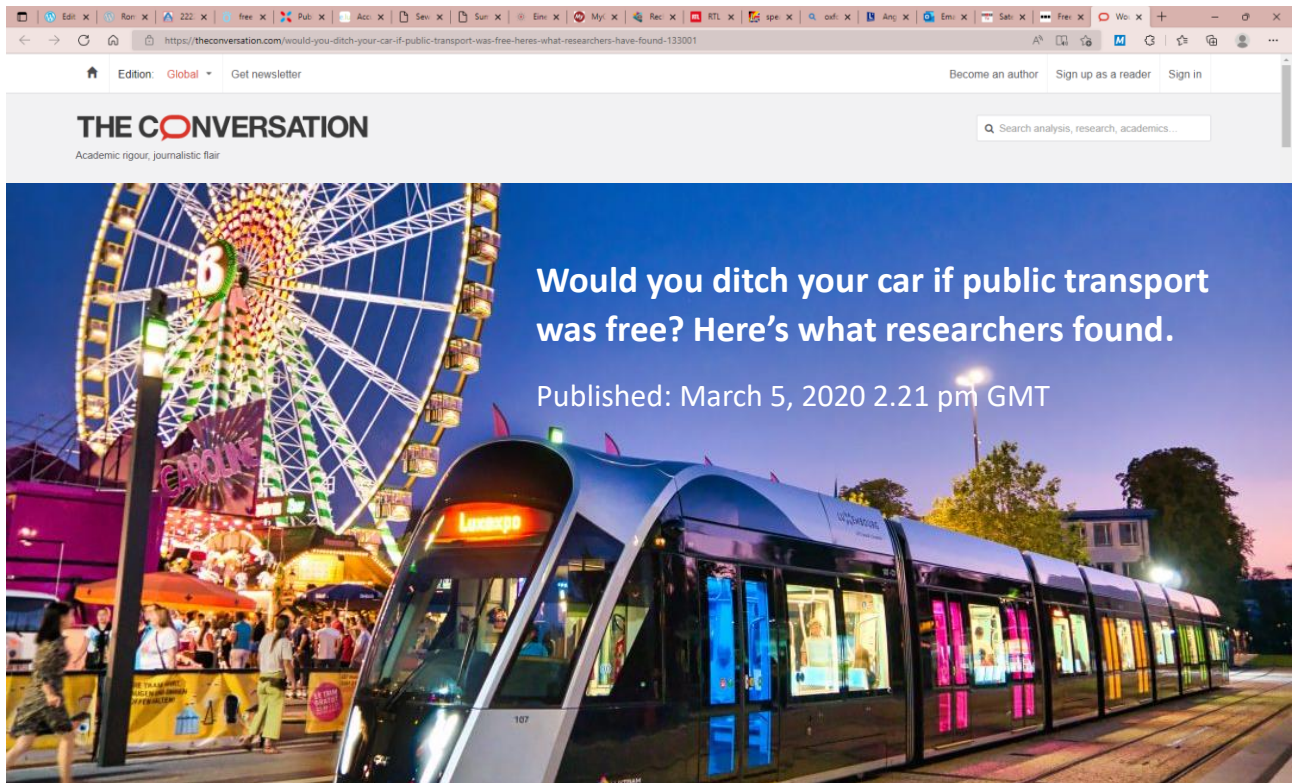

Luxembourg recently became the first country in the world to make all public transport free. As of March 1, 2020, all buses, trains and trams throughout the country can be boarded without paying a fare – the largest area to institute free public transport for both residents and tourists so far.

Free public transport, however, isn't a new idea. Cities and towns have been experimenting with it since 1960 – Luxembourg merely clinches the title of the first country to roll it out nationwide. Today, at least 98 cities and towns around the world have some form of free public transport. In some areas, only residents can use it, or certain groups, such as senior citizens.

It's often introduced to encourage people to use their cars less – reducing congestion in cities and lowering air pollution and carbon emissions.

But does it work?

No ticket to ride

Economists tend to argue that free public transport is irrational and uneconomical because it generates “useless mobility”. This means that people will choose to move more simply because it's free, increasing the costs of transport operators and subsidies for local authorities, while ultimately increasing emissions from public transport.

Perhaps it's no surprise that introducing free public transport increases the number of people using it. Strong passenger growth has been reported everywhere free public transport has been introduced, and the effects are more evident after several years.

¹ [Would you ditch your car if public transport was free? Here's what researchers have found \(theconversation.com\)](https://theconversation.com/would-you-ditch-your-car-if-public-transport-was-free-heres-what-researchers-have-found-133001)
<https://theconversation.com/would-you-ditch-your-car-if-public-transport-was-free-heres-what-researchers-have-found-133001>

Research has also found that when fares are removed, only a small number of people who previously travelled by car make the switch. New passengers attracted by it tend to be pedestrians and cyclists rather than car drivers. The picture from most cities where free public transport has been introduced is that the increased passenger numbers overwhelmingly come from people who might have walked, cycled or not travelled otherwise.

Three years after fares were abolished in Estonia's capital, Tallinn, the number of bus passengers increased from 55% to 63%, while car journeys decreased only slightly (from 31% to 28%), together with walking (from 12% to 7%), cycling (1%) and others (1%) remained the same.

Experts from the Cosmopolis Centre in Brussels agree that the effects of free public transport on car traffic levels are marginal, arguing that by itself free public transport cannot significantly reduce car use and traffic, or improve air quality. What can? Well, the researchers found that the behaviour of motorists and the transport mode they choose depends very little on public transport fares. Rather than relying on free public transport to engineer the shift, a more effective way to reduce the number of people choosing to drive could be regulating car use.

Increasing the cost of parking, congestion charging, or increasing fuel taxes could all be combined with free fares to lower car demand.

How successful fare abolition is at tempting people to use buses and trams depends on the quality of the service. Cleaner and more reliable public transport must be a prerequisite for these schemes if buses and trams are to compete with the car and making it part of a wider investment plan could have a big impact on the sustainability of transport.

Fare abolition can help to make public transport visible as a valid alternative to the car in cities where many residents might have forgotten about it over time, due to chronic underinvestment.

Free public transport may not be effective for making transport sustainable on its own, but it can have plenty of other benefits that make it worthwhile. It can be a progressive social policy, guaranteeing and improving access to public transport for diverse groups that might otherwise struggle to get around.



Lexis

Find words and expressions in the text which refer to the following kinds of people

1. people who live in a particular place and who have their home there
2. people who are travelling in a car, bus, train, plane or ship and who are not driving it or working on it
3. people walking in the street and not travelling in a vehicle
4. people driving a car

Find words and expressions in the text which mean

1. all over, in every part of a place
2. to get on a bus, boat, aircraft, etc.
3. the money that you pay to travel by bus, plane, taxi, etc.
4. to start a plan, law, system, etc.
5. to finally get or win something
6. to officially make a new product, service or system available for the first time
7. happening or existing in all parts of a particular country
8. the state of being crowded and full of traffic so that movement is difficult
9. to reduce
10. an increase in size, amount or degree of something
11. in a way that is very great or very strong; in a way that is so powerful that you cannot resist it or decide how to react
12. very small in amount or effect
13. change in position or direction
14. to control something by means of rules
15. any substance that produces heat or power, usually by being burnt
16. the act of ending of a law, a system or an institution officially
17. who or which can be trusted or believed because he, she, or it behaves well in the way one expects
18. something that must exist or happen before something else can exist or happen
19. involving the use of natural products and energy in a way that causes little or no damage to the environment and therefore able to continue for a long time
20. varied, including many different types of people or things

Comprehension

Decide if the sentences below are true or false. Tick the respective box. If there is not enough information in the text, tick '?'.

	True	False	?
1. Luxembourg is the only city with free public transport.	<input type="checkbox"/>	<input type="checkbox"/>	<input type="checkbox"/>
2. People move more when public transport is free	<input type="checkbox"/>	<input type="checkbox"/>	<input type="checkbox"/>
3. From an economic point of view, free public transport does not make sense.	<input type="checkbox"/>	<input type="checkbox"/>	<input type="checkbox"/>
4. Car drivers tend to give up driving when public transport is free.	<input type="checkbox"/>	<input type="checkbox"/>	<input type="checkbox"/>
5. To lower the use of cars effectively, authorities should combine a number of measures.	<input type="checkbox"/>	<input type="checkbox"/>	<input type="checkbox"/>
6. Public transport should be a high-quality service with clean carriages and trains arriving on time.	<input type="checkbox"/>	<input type="checkbox"/>	<input type="checkbox"/>
7. There are places where people do not even think about the possibility to use public transport because the service has not been kept in good condition.	<input type="checkbox"/>	<input type="checkbox"/>	<input type="checkbox"/>
8. There are social groups who find it difficult to travel around if there is no public transport.	<input type="checkbox"/>	<input type="checkbox"/>	<input type="checkbox"/>
9. Free public transport does not have any positive effects.	<input type="checkbox"/>	<input type="checkbox"/>	<input type="checkbox"/>

Free public transport

In Luxembourg, public transport (trams, trains and buses) is free for everybody (residents, cross-border commuters, tourists). Take advantage of this opportunity to discover the country.

For more information on how to get around in Luxembourg, go to <https://www.mobiliteit.lu/en/>

Online information about places to visit in Luxembourg

The official portal of the Grand Duchy of Luxembourg is

<https://luxembourg.public.lu/en.html>

Moreover, there are a lot of tourist offices and 'syndicats d'initiatives' that give you information on what you can discover and experience in different places Luxembourg.

Go to the following online travel guide for information on the whole country.

- <https://www.visitluxembourg.com/>

Go to the following online travel guides for information on the respective regions.

- <https://www.visit-eislek.lu/en> on the Ösling in the north of the country.
- <https://www.visitmoselle.lu/en> on the Moselle region in the southeast of the country.
- <https://www.mullerthal.lu/en> on the Müllerthal in the northeast of the country.
- <https://www.visitminett.lu/en> on the Redrock region in the south of the country.

Go to the following online travel guides for information on the respective cities.

- <https://www.luxembourg-city.com/en>
- <https://www.visit-diekirch.lu/en>
- <https://www.visit-vianden.lu/en>

Go to the websites of the English-speaking expatriate community for information for newly arrived people.

- <https://smartexpat.com/luxembourg/how-to-guides/lifestyle/activities-days-out/tourist-offices>

For information on shopping, go to

- <https://www.cityshopping.lu/en>

1. ANSEMBOURG

Ansembourg castle



Address

10, rue de la Vallée
L-7411 Ansembourg
Tel.: +352 30 88 41 31 6
info@gcansembourg.eu
www.gcansembourg.eu



Ansembourg is a village in the west of the country. It is located in the farming country of the valley of the Eisch. The castle of Ansembourg dates from the 12th century. The modern manor house was built in the first half of the seventeenth century by Thomas Bidart as "maison de maître de forges". Thomas Bidart was a pioneer of the iron industry. In the eighteenth century, the Grand Castle Ansembourg experienced significant transformations when the heirs of Thomas Bidart found themselves elevated to nobility.

The French gardens of Ansembourg Castle

The baroque gardens were devised by Count Lambert-Joseph in 1750. They are laid out in terraces. The castle is not open to the public, but the gardens can be visited (a guided tour of the gardens can be booked upon request). Comprising statues, fountains, stairs, botanic collections, exotic plants and numerous varieties of fruit trees, these gardens are well worth visiting.

Opening times

Please consult the website.

Services

Visit of the gardens possible



Guided tour of the building and the gardens

Upon request

Entrance fees

Free access to the gardens.

Identify the different forms of the verb 'to be' in the text. Which tense are they in?

2. BERDORF

Aquatower Berdorf

Address

106, rue de Consdorf
L-6551 Berdorf
Tel.: +352 79 01 87 37
aquatower@berdorf.lu
www.aquatower-berdorf.lu



Dive into the fascinating world of drinking water and visit the 55-meter high Aquatower in Berdorf. The Aquatower is home to an exhibition on water and offers spectacular views on the surroundings of Berdorf. Activities about water are also available.

The exhibition about the themes "Water and Geology" is located at a height of 32 meters and offers a variety of interactive stations that present information to refresh and develop one's knowledge about the vital (=necessary for life) element water.

Opening times

March to November

01.03. – 31.03.	Saturday – Sunday	14:00 - 17:00
01.04. – 30.06.	Tuesday - Sunday	14:00 – 18:00
01.07. – 15.07.	Tuesday - Sunday	10:00 – 18:00
16.07. – 14.08.	Monday - Sunday	10:00 – 18:00
15.08. – 31.08.	Tuesday - Sunday	10:00 – 18:00
01.09. – 31.10.	Tuesday - Sunday	14:00 – 18:00
02.11. – 30.11.	Saturday - Sunday	14:00 – 17:00

December to February

Only upon request (= demand)

Services

Disabled access



Guided tour



Cafeteria



Shop



Entrance fees – cash only

Adults

3,50€

Children and teenagers (7 – 18 years)

2€

Children (up to 7 years)

Free

Groups (10 people or more)

2€ per person

Comprehension

Read the text and decide if the sentences below are true or false and tick the respective box. If there is not enough information in the recording, tick '?'.

	True	False	?
1. It is possible to taste drinking water at the Aquatower.	<input type="checkbox"/>	<input type="checkbox"/>	<input type="checkbox"/>
2. The exhibition is set up at the top of the tower.	<input type="checkbox"/>	<input type="checkbox"/>	<input type="checkbox"/>
3. The Aquatower offers people a bird's eye view of the land around it.	<input type="checkbox"/>	<input type="checkbox"/>	<input type="checkbox"/>
4. The exhibition in the Aquatower has a number of interactive stations.	<input type="checkbox"/>	<input type="checkbox"/>	<input type="checkbox"/>
5. The Aquatower CANNOT be visited in winter.	<input type="checkbox"/>	<input type="checkbox"/>	<input type="checkbox"/>
6. Disabled visitors get a discount.	<input type="checkbox"/>	<input type="checkbox"/>	<input type="checkbox"/>

How does a water tower work?

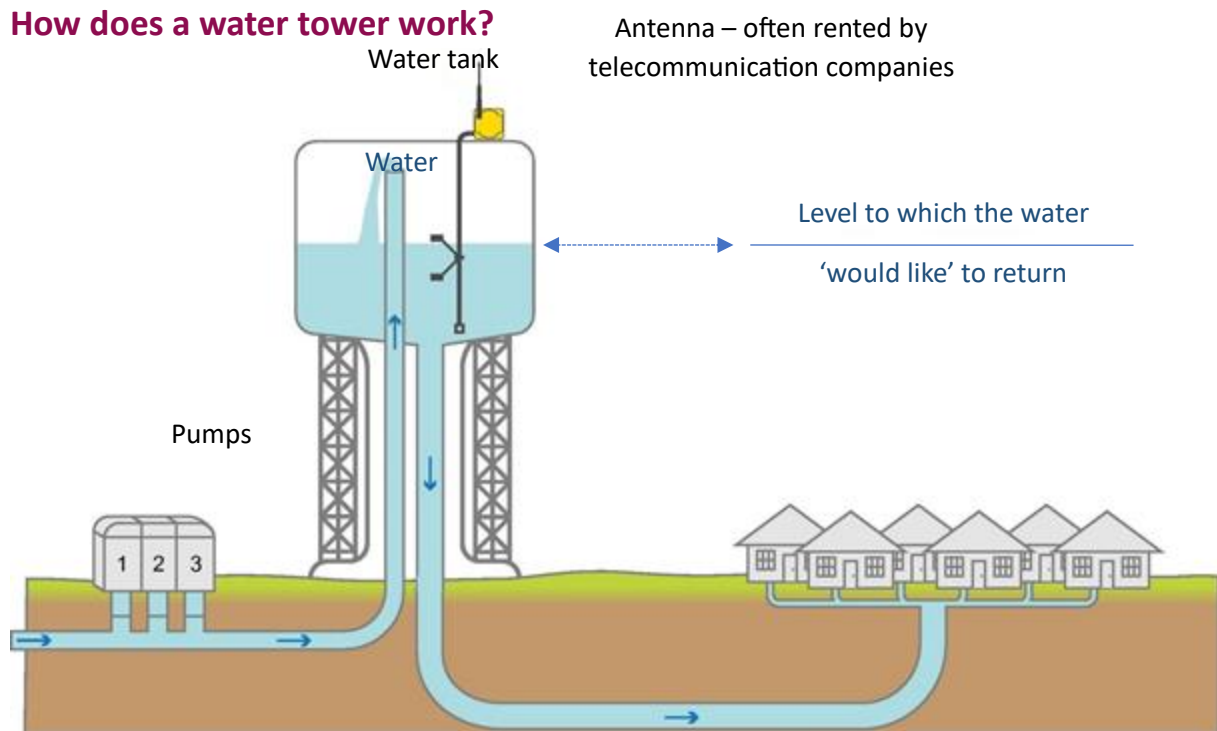

First, the water is treated so that it is safe to drink.

The drinking water is stored before powerful pumps pushed it up of the water into a huge water tank.

The height of the tower generates pressure. When the water is released from the tank, it 'would like' to return to the same level as in the tank.

Note: You can build your own water level!



If you want to hang up shelves or pictures, and, if you do not have a construction spirit level from a DIY shop, you can build your own water level device. All you need is a transparent plastic tube which is filled with water. If you hold the ends up vertically, the water level at each end of the tube will be at the same elevation, whether the two ends are adjacent or far apart.



3. BETTEMBOURG

Fairy tale park



Address

Route de Mondorf
L-3260 Bettembourg
Tel.: +352 51 10 48 1
Fax: +352 52 45 11
parc@parc-merveilleux.lu
www.parc-merveilleux.lu

The fairy tale park in Bettembourg is the only leisure park in the Grand Duchy of Luxemburg. On 25 hectares land, visitors find peace and quiet as well as relaxing entertainment. To mention just a few attractions, for young children there are the forest of fairy tales, the petting zoo and several playgrounds, and for the entire family, there are exotic animals from five continents to discover. There is, for instance, a giant spider's web where children can go climbing safely. There is a dark maze out of which they have to find their way. And finally, there is the village of birds where they can see the world from up above. There are pelicans and pink flamingos to be observed near the lake. There are enclosures with monkeys and crocodiles. In the Amazon house, there is a huge aquarium where visitors can admire the elegance of penguins under water. In the forest there are shady spots to rest as well as areas for exploration and discovery.

Opening times

01.04. – 08.10.

Wednesday – Sunday

09:30 - 18:00

Services

Disabled access

x

Guided tour

x

Cafeteria

✓

Shop

✓

Entrance fees

Adults

10€

Children and teenagers (3 – 14 years)

7€

Find the names of the animals below in the text.

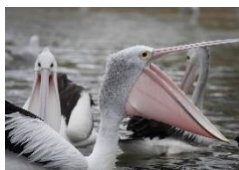

Comprehension

Read the text and decide if the sentences below are true or false and tick the respective box. If there is not enough information in the recording, tick '?'.

	True	False	?
1. There is only one theme park in Luxembourg.	<input type="checkbox"/>	<input type="checkbox"/>	<input type="checkbox"/>
2. The fairy tale park has a lot of thrilling rides.	<input type="checkbox"/>	<input type="checkbox"/>	<input type="checkbox"/>
3. The fairy tale forest is meant to entertain very young visitors.	<input type="checkbox"/>	<input type="checkbox"/>	<input type="checkbox"/>
4. There is a lake in the park.	<input type="checkbox"/>	<input type="checkbox"/>	<input type="checkbox"/>
5. Visitors can go swimming with the penguins.	<input type="checkbox"/>	<input type="checkbox"/>	<input type="checkbox"/>
6. There is a climbing frame which is like huge 'spider's web'.	<input type="checkbox"/>	<input type="checkbox"/>	<input type="checkbox"/>
7. There is NOT a lot of light in the maze.	<input type="checkbox"/>	<input type="checkbox"/>	<input type="checkbox"/>
8. Guided tours of the park are organized upon request.	<input type="checkbox"/>	<input type="checkbox"/>	<input type="checkbox"/>

Proofread and edit the text on the wallaby, an animal you can see in the Fairy Tale Park.

The wallaby

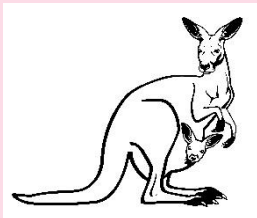

a wallaby is a marsupial, i.e. animal with a pouch, that is a member (**of / off**) the kangaroo family. wallabies are smaller (**than / then**) kangaroos and distributed widely across australia and the neighbouring islands. most wallaby species are small, but some can grow up to approximately (**to / too / two**) metres in height (from head to end of tail). wallabies have very powerful tails and hind legs. wallaby tails are used (**for / four**) support when sitting as well as for balance. the hind legs are used for hopping along at high speeds and for jumping great distances. when fighting, males use their hind

legs to deliver powerful kicks. wallabies tend to live in more remote areas which are wooded or rugged. wallabies are herbivores: (**their / there**) diet consists of plants and grasses. some species of wallaby live in areas where there is no fresh water, they drink plant juices. some of them can even drink salty sea water. young wallabies are born very small and vulnerable. as soon as they are born, they crawl into their mother's pouch where they continue to develop. unfortunately, many wallaby species are endangered. wallabies need our help.

Punctuation

Find 14 missing capital letters

Spelling

Circle the correct spelling where a choice of words is given.

Grammar

Find the adjectives that tell us something about the following nouns from the text.

- _____ Islands
- _____ Tails
- _____ Legs
- _____ Speeds
- _____ Areas
- _____ Species

The text indicates that 'exotic animals from five continents will fascinate the entire family'. In fact, visitors can discover about 200 species coming from Africa, America, Asia and Europe, as well as Australia.

Match the continents and parts of continents (1-6) with the animals (a-j) they are home to.

1.  AFRICA

2.  NORTH AMERICA

3.  SOUTH AMERICA

4.  ASIA

5.  AUSTRALIA

6.  EUROPE



a. alpaca



b. emu



c. fallow deer



d. fennec (fox)



e. katta (lemur)



f. macaw (parrot)



g. peacock



h. Poitou donkey



i. porcupine



j. racoon



k. wallaby (kangaroo)



l. zebu

Write your answers here

1	2	3	4	5	6

4. DIEKIRCH

National Museum of Military History



Address

10, rue Bamertal
L-9209 Diekirch
Tel.: +352 80 89 08
reception@mnhm.lu
www.mnhm.lu



The National Military History Museum in Diekirch tells the story of the Battle of the Bulge (1944-45). Some of the main exhibits are detailed life-size models that give clear views of the struggles faced by soldiers and civilians. As well, there are permanent exhibitions dedicated to the Luxembourgish Army, allied soldiers in the First and Second World Wars, and the Korean War. There is a large collection of military equipment, vehicles, documents, photos, maps, personal items, and more.

Opening times

01.01. – 31.12.

Tuesday – Sunday

10:00 - 18:00

Services

Disabled access



Guided tour



Cafeteria



Shop



Entrance fees

Adults

5€

Military in uniform

3€

Children, teenagers (12 – 18 years) and students

3€

Children (up to 10 years)

free

Disabled people

free

Groups (10 people or more)

3€ per person



5. ETTTELBRÜCK

General Patton Memorial Museum

Address

5, rue Dr. Klein
L-9054 Ettelbruck
Tel.: +352 81 03 22
patton@patton.lu
www.patton.lu

The museum, which was officially inaugurated in 1995, pays tribute to General George S. Patton Jr., whose 80th infantry division liberated the town of Ettelbrück on 25 December 1944. In addition to the imposing statue of General Patton there are over 1000 photographs and documents that bear witness to the German invasion in May 1940, the Nazi occupation and the liberation by American troops in September 1944. Another part of the exhibition presents to the visitor a considerable number of weapons and military equipment, discovered on the battlefield of the Bulge in recent years. Finally, visitors are given an overview of the air war in Luxembourg.

Opening times

01.01. – 31.12.

Tuesday – Sunday

10:00 - 17:00

Services

Disabled access



Guided tour



Cafeteria



Shop



Entrance fees

No information available

Comprehension

Read the two texts and decide which museum the following statements refer to. If there is not enough information in the recording, tick '?'.
 Museum in Diekirch Ettelbrück ?

	Museum in	Diekirch	Ettelbrück	?
1. The museum is dedicated to a war hero.		<input type="checkbox"/>	<input type="checkbox"/>	<input type="checkbox"/>
2. The museum is concerned with World War I.		<input type="checkbox"/>	<input type="checkbox"/>	<input type="checkbox"/>
3. The museum is concerned with World War II.		<input type="checkbox"/>	<input type="checkbox"/>	<input type="checkbox"/>
4. The museum is concerned with other wars.		<input type="checkbox"/>	<input type="checkbox"/>	<input type="checkbox"/>
5. The museum has an exhibition on military uniforms.		<input type="checkbox"/>	<input type="checkbox"/>	<input type="checkbox"/>
6. There are reproductions of war scenes at the Museum.		<input type="checkbox"/>	<input type="checkbox"/>	<input type="checkbox"/>
7. The museum is particularly concerned with the 'Battle of the Bulge'.		<input type="checkbox"/>	<input type="checkbox"/>	<input type="checkbox"/>
8. The museum has an exhibition on the Luxembourg armed forces.		<input type="checkbox"/>	<input type="checkbox"/>	<input type="checkbox"/>

Lexis

The army – word search

Find the words to refer to the pictures. Use an online dictionary to look up words you do not know. There is an example.

							
	<p>A C S W E G Z F P H T J F N I V I L O N Y N J E Z W G I L V A V R A L U Q L F R T L G Q V L M S C G D I B M O R C H O O D P M D R C I T R J I K T W T U T N E O A E E K H G Q E B Z L A E P D G F N R O G H R M U H G T L R A E T I G E O J E C R E U A L D L K C M R L E W E R U T W Z U Q E T A D G T I U E R I E E U B O T B R N G F U R T Z D R O N E V R L R A N A T P H A M I S S I L E K I L G A A V N I X U O K G K F T E X N U G E N I H C A M O Z E O R K L E R E F A D G R F Q M Y C H A N G L K P A M K L B L G C I S N O P A E W P M I B E E L M W I P R O R Q K C H I H A P W J V N I V H V P O K V X Z K</p>						
							
							
							
							

5. GREVENMACHER

The Butterfly Garden - Päiperlecksgaart

Address

56, Route de Trèves
L-6793 Grevenmacher
Tel.: +352 75 85 39
papillons@elisabeth.lu
www.papillons.lu



The butterfly garden is the ideal place for lovers of nature and its beauties. Located in the wine town of Grevenmacher, you can take a walk in our over 600 m² tropical garden and admire the hundreds of exotic butterflies. With a constant temperature of 27° Celsius and humidity of 70%, the tropical garden is a paradise-like oasis on the shores of the Moselle for butterflies from all over the world. Discover the fascinating life cycle of the butterfly. After mating, the females lay their eggs which develop into caterpillars. When the cocoon tissue has ripened the caterpillar transforms inside into a chrysalis in order to end up as a marvellous butterfly. Thanks to the tropical climate in the greenhouse, the butterfly garden in Grevenmacher has also become the habitat of numerous Asian Blue quails, chameleons, turtles, some birds and a captive colony of bees. Multi-coloured flowers and our garden's idyllic atmosphere will send you dreaming.

Opening times

01.04. – 31.10.

Monday – Sunday

09:30 - 17:00

Services

Disabled access

✓

Guided tour

Upon request

Cafeteria

✓

Shop

✓

Entrance fees

Adults

8€

Disabled adults

7€

Children (up to 12 years)

5€

Disabled children (up to 12 years)

4€

Teenagers and students

6,5€

Groups (10 people or more)

- Adults

7€

- Disabled adults

6€

- Children (up to 12 years)

4€

- Disabled children (up to 12 years)

3€

- Teenagers and students

5,5€

Comprehension

Find the butterflies

Match the pictures (1-8) with the descriptions of the butterflies (a-h). Write their names under the respective pictures.



1.



2.



3.



4.



5.



6.

- a. The male **BRIMSTONE** has a sulphur yellow wing coloration. The wings have a fine orange spot each.
- b. The **CABBAGE BUTTERFLY** or **LARGE WHITE** is basically creamy white. The tips of the forewings are dark brown, and there is at least a dark spot on each wing.
- c. The **PEACOCK BUTTERFLY** has basically a rusty red colour. On each wingtip, there is a distinctive, black, blue and yellow eyespot.
- d. The **RED ADMIRAL** has a striking black, orange, and white wing pattern. The forewings have orange bands / stripes in the middle and the outer edge of the hindwings is orange, too. The ends of the forewings contain white spots.
- e. The **SMALL TORTOISE SHELL** is mainly reddish orange, with black and yellow stripes on the forewings as well as a ring of blue spots around the edge of the wings.
- f. The **SWALLOWTAIL** typically has yellow wings with black vein markings, and a wingspan of 65–86 millimetres. The hindwings have one red and six blue eye spots. The hindwings also seem to have ‘tails’ which give the butterfly its common name from the resemblance to the birds of the same name.



The life cycle of a butterfly

The life span of an adult butterfly is normally rather short. A few adults live for 18 months, while most of them last no more than two weeks. Throughout their life butterflies undergo a series of massive changes known as metamorphosis and take on different shapes. The shapes include: egg, caterpillar or larva, chrysalis or pupa, and adult.

Identify the different shapes of the butterfly represented in the pictures below.



Now describe the different stages of the metamorphosis.

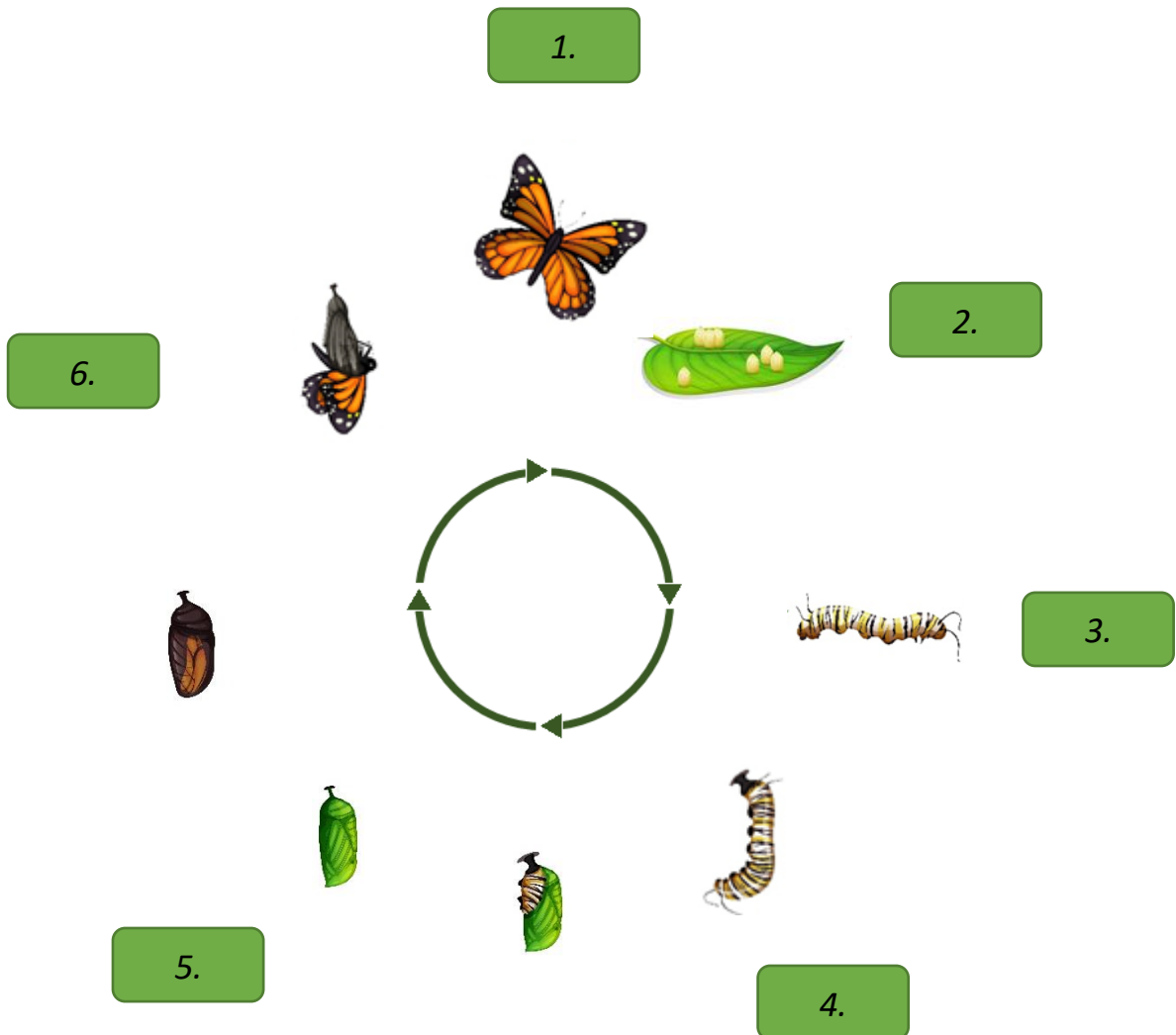

a. A fully-grown caterpillar finds a safe place to pupate (change into a pupa, or chrysalis). Some caterpillars spin cocoons of silken threads in which they pupate.

b. All butterflies start off as eggs. Some of the tiniest eggs are smaller than a millimeter, and almost all are yellow or green. Female butterflies tend to lay eggs on plants that their caterpillars will find tasty. Some eggs hatch in a few days, while others take months.

c. In one day, a caterpillar can eat many times its weight in food. Most of the food is stored as fat for later stages of life, such as the metamorphosis from caterpillar to adult - a time when the butterfly can't eat.

d. Inside, the creature is undergoing amazing chemical changes, and gradually the adult butterfly emerges.

e. The main thing a caterpillar (or larva) does, is eat and eat and eat. It often eats its own eggshell and then begins to eat the plant it was laid on. Caterpillars must molt or, in other words, shed their skin, in order to grow. Most of them do this four or five times over a period that lasts at least two weeks.

f. When the metamorphosis is complete, the adult butterfly breaks out of its pupa shell or cocoon. Its wings and body are still soft, so it pumps blood into its newly formed wings. Within about half an hour, the exoskeleton hardens, and the wings become rigid. The new adult's task is to find a mate.

Write your answers here

1	2	3	4	5	6

Caterpillars to butterflies

this is how caterpillars tern into butterflies
 a female buterfly lays eggs on a green leaf
 after about ten days tincy caterpillars hatch
 they begin to look for food the catarpillars grow
 and grow as they continue to eat when thay
 are fully grown, eatch caterpillar changes into a
 chrysalis after about two weeks,
 out cum colourful butterflies

Punctuation

Find 7 missing capital letters and 7 full stops.

Spelling

One word in each line has been misspelled. Underline it and write the correct spelling on the line on the right.

Write the plural of each word.

caterpillar _____
 egg _____
 day _____
 week _____

Grammar

Adjectives are words which describe nouns. Write adjectives from the text that describe these nouns.

butterfly
 butterflies
 caterpillar
 leaf

6. MUNSHAUSEN

Tourist Centre 'Robbesscheier'

Address

1, Frummeschgaass
L-9766 Munshausen
Tel.: +352 92 17 45 1
Fax: +352 92 93 47
info@touristcenter.lu
www.touristcenter.lu

Discover the lifestyle of our ancestors in 14 exciting and interactive workshops, you can witness how our Blacksmith adapts a new horseshoe, discover how our beekeeper maintains the bee colonies, learn everything about the production of honey, operate old agricultural machinery, visit our old sawmill and learn more about the hay harvest.

Learn how farmers once lives with all your senses; see, hear, feel, taste, on a 6-acre site in Munshausen, in the yard in Cornelyshaff Heinerscheid with the small craft brewery in the Water Mill "Rackésmillen in Enscherange.

Opening times

01.03. – 01.01.

Monday – Sunday

10:00 - 17:00

Monday -Tuesday

Open on public holidays

Services

Disabled access



Guided tour



Cafeteria / Restaurant



Shop



Label the pictures below with the words form the box.

farm house with
barn and stables
fields

garden
meadow

orchard
vineyard



7. ROSPORT

Henri Tudor Museum Rosport

Address

9, rue Henri Tudor
L-6582 Rosport
Tel.: +352 73 00 66 206
Fax: +352 73 04 26
info@musee-tudor.lu
www.musee-tudor.lu



The Henri Tudor interactive museum is devoted to scientific research in general and the work of Henri Tudor in particular.

In the interactive museum about electricity and batteries, you can get into the world of Henri Tudor, a man who dedicated his life to the science of electricity. Oil lamps and farming sounds take you back in the 19th century and allow you to understand what electricity is as well as to discover the evolution of the electrical technology thanks to hands-on activities.

As for Henri Tudor himself, you will find out what his contribution on the storage of energy or the use of electricity for the lighting of cities was. Tudor's lead battery played a supporting role and gave further impetus to the development of today's technology.

Opening times

01.03. – 01.01.

Wednesday – Sunday

12:00 - 18:00

Monday -Tuesday

Open on public holidays

Services

Disabled access



Guided tour



Cafeteria



Shop



Entrance fees – cash only

Adults

4€

Children, teenagers and young adults up to 21 years as well as students with a student card

free

Groups

60€

Henri Tudor driving his electric-powered shooting brake built in 1902 by J. Lefert, coachbuilders, in Ghent and – no doubt – equipped with Tudor batteries



Put the verbs in brackets into the correct tense and form.



Henri Owen Tudor

Henri Owen Tudor (30 September 1859 – 31 May 1928) was a Luxembourgish engineer, inventor, and industrialist who developed the first commercially usable lead-acid battery.

Henri Tudor (a) _____ (to be) the son of John Thomas Tudor from Llanarth (United Kingdom) and Marie Loser from Rosport. He (2) _____ (to attend) the primary and secondary school as a boarder at the municipal College of Chimay (Belgium), and (3) _____ (to be) a student from 1879 to 1883 at the École Polytechnique, which (4) _____ (to be) part of Brussels University. In 1885, the young engineer (5) _____ (to specialize) at an electrical engineering institution in Paris, where he (6) _____ (to attend) the lectures given by Marcel Deprez.

Henri Tudor (7) _____ (to be / always) interested in electricity and especially in its storage. He (8) _____ (to develop) an electric lighting system in his father's residence, the Irminenhof in Rosport, even before he had completed his engineering studies. During his vacations, he (9) _____ (to connect) a Gramme type generator to the water-wheel of the Bannmillen, a mill located on the lower part of the property. Wires (10) _____ (to carry) the electric energy from the mill to the house, which (11) _____ (to illuminate) with Edison light bulbs. The power (12) _____ (to supply) by the generator was obviously irregular. Furthermore, it (13) _____ (not to use) during off-peak hours. Henri Tudor (14) _____ (to have) the idea of using lead acid accumulators as a buffer — to equalise the voltage and to store the unused energy.

The chemical reactions occurring in a lead-acid battery or accumulator (15) _____ (to observe / first) by Wilhelm Josef Sinsteden in 1854. The accumulator as a rechargeable battery (16) _____ (to invent) in 1859 by Gaston Planté and (17) _____ (to improve) in 1880 by Camille Faure. In its practical applications, it (18) _____ (to prove) however to be unreliable: short circuits (19) _____ (occur), and the plates (20) _____ (to fall) apart during service. Thomas Edison (21) _____ (to describe) the lead-acid accumulator as a "a catchpenny, a mechanism for swindling the public" and "commercially a failure."

Henri Tudor (22) _____ (to seek – to seek, sought, sought) a permanent solution to these problems and (23) _____ (to manufacture) himself a mould for casting large surface plates with which he (24) _____ (to build) a lead-acid accumulator of his own design. Doing so, he (25) _____ (can) rely on the help of his brother Hubert, and of his cousin, Nikolaus Schalkenbach of Trier. With the combined equipment — generator and buffer battery — he (26) _____ (to be) able to run continuously and constantly the power supply of the Irminenhof, which thus (27) _____ (to become) the first private home in Luxembourg to have electric lighting.

The Tudor electrode (28) _____ (to stand out) because of its unequalled reliability. We (29) _____ (to know) from a reliable source that a Tudor accumulator (30) _____ (to be) put into service in October 1882 and that it (31) _____ (to run) without any interruption until December 1887. Accumulator plates having been in regular service for 16 years (32) _____ (to exhibit) in the Tudor Museum in Rosport.

On 5 May 1891, Henri Tudor (33) _____ (to marry) Marie-Madeleine Pescatore from Bofferdange. They (34) _____ (to have) three children and the young family (35) _____ (to move) in September 1892 into their newly built monumental Manor House in Rosport.

In 1914, Henri Tudor (36) _____ (to begin) to suffer from lead poisoning which (37) _____ (to cause) his death in 1928.

Comprehension

**Read the text and decide if the following statements are true or false.
If there is not enough information in the text, tick ☐ the box under '?'.**

		True	False	?
1.	Henri Tudor invented the lead-acid battery.	<input type="checkbox"/>	<input type="checkbox"/>	<input type="checkbox"/>
2.	Henri Tudor had British origins.	<input type="checkbox"/>	<input type="checkbox"/>	<input type="checkbox"/>
3.	Henri Tudor started experimenting with electricity when he went to school in Chimay.	<input type="checkbox"/>	<input type="checkbox"/>	<input type="checkbox"/>
4.	Henri Tudor tried out some of his inventions on his father's property.	<input type="checkbox"/>	<input type="checkbox"/>	<input type="checkbox"/>
5.	Lead-acid batteries often broke down in the beginning.	<input type="checkbox"/>	<input type="checkbox"/>	<input type="checkbox"/>
6.	Thomas Edison considered lead-acid batteries as a must-have.	<input type="checkbox"/>	<input type="checkbox"/>	<input type="checkbox"/>
7.	Henri Tudor started a family business with his brother and his cousin to manufacture batteries.	<input type="checkbox"/>	<input type="checkbox"/>	<input type="checkbox"/>
8.	Henri Tudor renovated the Irminenhof in Rosport as a home for his family.	<input type="checkbox"/>	<input type="checkbox"/>	<input type="checkbox"/>
9.	Homes in Luxembourg had electric lighting thanks to Henri Tudor's inventions.	<input type="checkbox"/>	<input type="checkbox"/>	<input type="checkbox"/>
10.	Henri Tudor died due to health problems linked to his work.	<input type="checkbox"/>	<input type="checkbox"/>	<input type="checkbox"/>

How does a lead-acid battery, i.e. a car battery, work?

Lead-acid batteries are composed of a sponge metallic lead anode. A lead-dioxide cathode and a sulphuric acid electrolyte. The heavy metal element makes them toxic and improper disposal is dangerous for the environment.

Terminals This is where energy leaves **Casing** The six galvanic cells are held in position by a non-reactive plastic lead – a good corrosion-resistant composite case. conductor.

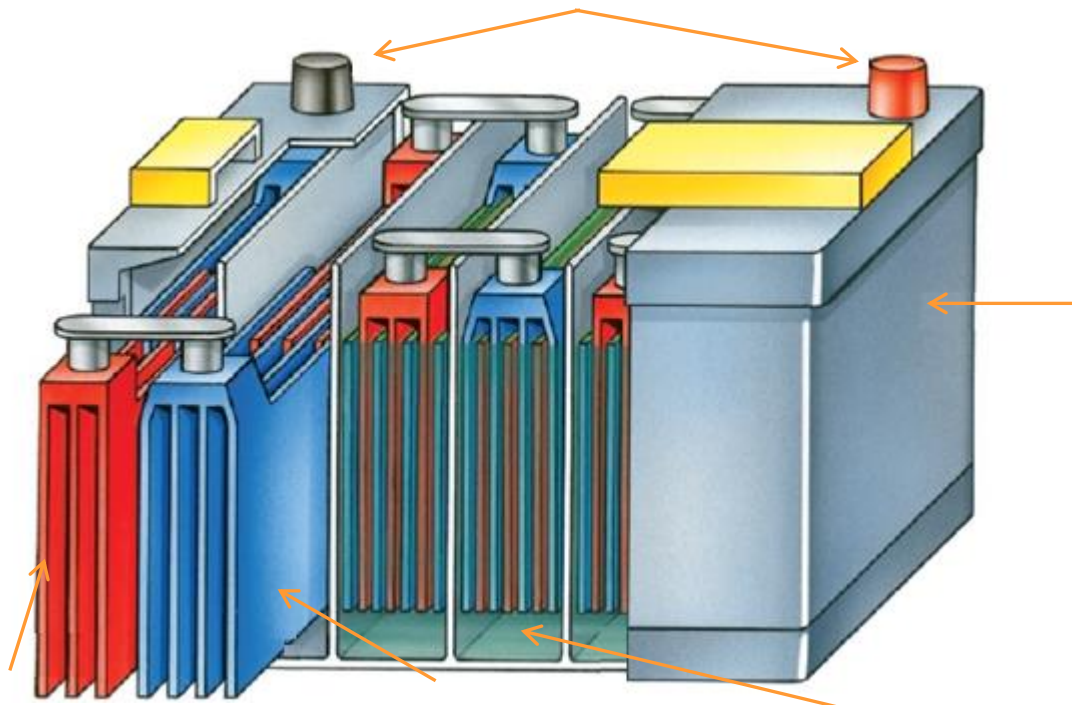

Lead plate The negative electrode reacts with sulphuric acid to generate hydrogen ions and more lead sulphate. **Lead dioxide plate** This is the active material within the battery, reacting with the acid to produce ions and lead sulphate. **Sulphuric acid** The plates are submerged in acid which acts as the chemical catalyst and an electrolyte for ions.

Discharge During discharge, lead (negative plate) and the lead dioxide (positive plate) react with the electrolyte of sulphuric acid to create lead sulfate, water and energy.

Charge When charging, the cycle is reversed: the lead sulfate and water are electro-chemically converted to lead, lead oxide and sulphuric acid by an external charging source.

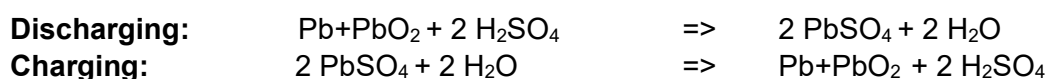
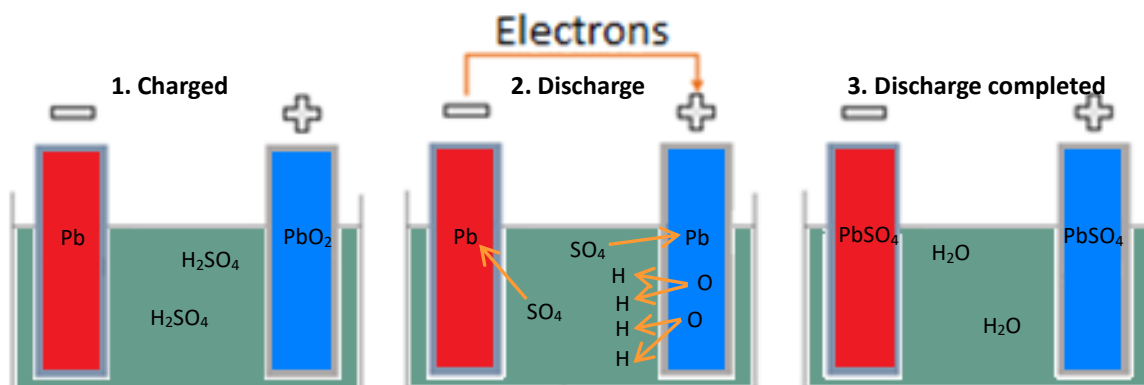

IV. Traditions and events



Read the descriptions of different Luxembourgish traditions.

Match the pictures (1 – 12) with the descriptions (a – N). There is an example (O,o)



a.

A few days before 6 December, the Kleeschen (Saint Nicholas) visits children in schools and communities accompanied by the Houseker (Père Fouettard) to hand out sweets or a whipping with his twigs! Then, on the night of 5 – 6 December, the children receive gifts and sweets.



b.

A grand harvest festival that takes place every year on Assumption Day, hosted by the village of Greiveldange. This occasion brings together an array of local artisans who showcase their products. First, the 'Wësch' – a bouquet of herbs, grains and vegetables – is blessed, followed by a feast of traditional Luxembourgish dishes.



O.

An old tradition in the Luxembourg Ardennes, when cattle are brought back to the stables; people carve scary faces out of beetroots to protect themselves and the animals from evil spirits and illness throughout the winter months - a Luxembourgish version of 'Halloween'.



C. Between Maundy Thursday and Easter Sunday, children walk around the streets three times a day playing wooden ratchets known as 'Klibberen', taking the place of the church bells that lay silent during these four days. They go from door to door collecting chocolate eggs and sweets.

d. Children celebrate Lichtmëssdag (Candlemas), the Christian 'festival of lights', going from door to door bearing handmade lanterns and singing in exchange for sweets.

e. Founded in 1340 by John the Blind, Count of Luxembourg and King of Bohemia, Glacis Square plays host to the largest funfair in Luxembourg and the Greater Region over a period of three weeks - a mixture of tradition, attraction and gastronomical delights.

f. Known as 'Geenzefest', this festival is held on Whit Monday in Wiltz, and honours the broom – a shrub with yellow flowers – with parade floats, floral decorations and music groups.

g. Pretzel Sunday, or 'Bretzelsonndeg' as it is known, marks the day men give a pretzel to their sweethearts to declare their love. If the feeling is mutual, the men receive an Easter egg from them three weeks later on Easter Sunday. The custom is reversed during leap years, where it's the turn of the women to offer a pretzel to the men.



Write your answers here

0	1	2	3	4	5	6	7	8	9	10	11	12
o												

h.

The Buergbrennen bonfire festival is held on 'Buergsonndeg', the first Sunday after Lent, and involves the lighting of a huge bonfire in villages and neighbourhoods across the Grand Duchy, to figuratively burn winter way.

i.

The Éimaischen 'Potters' Festival' is celebrated every Easter Monday, with traditional pottery markets in the City of Luxembourg and the village of Nospelt. Here you can buy the famous 'Peckvillercher': little bird-shaped clay whistles.

j.

The Octav (Octave) is celebrated over a fortnight, during which people embark on a pilgrimage to the Notre-Dame Cathedral in Luxembourg City to honour the Virgin Mary. The Octav Market on Place Guillaume II was established so that the pilgrims could eat and relax after church.

k.

To celebrate Luxembourg's National Day on 23 June, several events are organised in and around the capital, including the Changing of the Guard, the Te Deum cathedral service, a military parade, a 101-cannon salute, and a torchlit procession the night before, followed by a spectacular firework display.

l.

Whit Tuesday sees lots of people come to Echternach to watch the pilgrims parade through the streets of the town. This 'Dancing Procession' features on UNESCO's World Heritage List.

2. 'Allerhellegen' and 'Trauliicht'¹

Nights have become significantly longer, leaves are falling, and the last sunny days of autumn are giving way to wind and rain. Nowadays, this is the time when in Luxembourg the dead are remembered and when an old tradition from the North of the country - the 'Trauliicht' is being revived and reinstated.



All Saints

In Christian countries, 'Allerhellegen' – 'All Saints' Day' - is celebrated on 1 November. It is the feast of all the Christian saints, including those that were not canonised (declared as saints by the church) or whose sanctity is only known to God.

On this occasion, families gather in cemeteries to commemorate their deceased close ones and lay down candles, flowers and wreaths for their sake and memory. This is common practice throughout the country and is accompanied by a mass and the blessing of the graves.

'Allerséilen' on 2 November is 'the day of the souls'. It is dedicated to all the dead who, according to Catholic doctrine, are in purgatory and have not yet been fully united with God.



An activity for young and old: hollowed-out turnips are decorated with grimaces and placed in front of the house to keep evil spirits away.

© SIP / Sven Knepper

The 'Trauliicht', a way of driving evil spirits away

In the north of Luxembourg, a particular tradition is currently experiencing a revival: the 'Trauliicht'. In October and November, people hollow out turnips and 'decorate' them with horrible faces. Lit by a candle, these 'Trauliichter' are then placed on village walls and close to the windows of homes to protect the respective households against the souls of the dead and evil spirits, which are said to be particularly active on those days.

Until the 1970s the 'Trauliicht' was a widespread tradition in the Ardennes in northern Luxembourg. There has been a revival of the practice in the entire country since the 1990s when Halloween, the 'Americanised' version, became popular.

While the two variants share the same roots, the 'Trauliicht' is a more traditional, less commercial festival than its transatlantic equivalent.

Are the sentences below (1-10) true (a) or false (b)? If there is not enough information to answer 'true' or 'false', choose doesn't say (c).

1. The weather is bad in Luxembourg in autumn.
 a true b false c doesn't say

2. The 'Trauliicht' has always been a popular tradition.
 a true b false c doesn't say

3. The 'Trauliicht' is a festival that is only celebrated in Luxembourg.
 a true b false c doesn't say

4. There are saints that people don't know.
 a true b false c doesn't say

5. 'Allerhellegen' is celebrated all over Luxembourg.
 a true b false c doesn't say

6. The dead in Purgatory suffer a lot.
 a true b false c doesn't say

7. 'Trauliichter' are lamps that are above all used to illuminate houses.
 a true b false c doesn't say

8. The 'Trauliicht' tradition is replacing Halloween tradition in Luxembourg.
 a true b false c doesn't say

9. Businesses more money with Halloween than the 'Trauliicht' tradition.
 a true b false c doesn't say

10. The 'Trauliicht' and Halloween are related.
 a true b false c doesn't say



3. 'Bazar international'²

Cool surprises after summer



Summer is around the corner and the holiday break is upon us. We can't wait. Not only because we love breaks, but also because this will be the last break we get until the Bazar weekend 2023. From September onwards, we will be in a more than full-time race against the clock to prepare what can only be described as 'the best Bazar so far'. We have many changes, cool surprises and new features for our visitors.

All our news will be shared as soon as we can via our website and our social media, so please follow us on Instagram and Facebook if you want to be on top of it all.

For now, just block your calendars for the Bazar International 2023.

Bazar Weekend 2023

Friday 24 November
Saturday 25 November
Sunday 26 November

We wish you all a wonderful summer holiday!

The Bazar weekend – our main event

Our main event is what we are most famous for. During this fun-packed three-day event our visitors get to travel the world in a couple of hours (or a few days for our hard-core fans!). Our almost 60 beloved stands sell the most delicious foods, tongue-tingling drinks, and a myriad of non-food items, like arts, jewellery, clothing, bags, Christmas decorations, etc. that are either made in their country or typical for their country.

The great thing about the Bazar is that our visitors make the world a better place while enjoying a delicious drink or snack with friends. Why? Because all our profits are donated to wonderful and life-changing humanitarian projects around the world.

² Adapted from:

[Home \(bazar-international.lu\)](https://www.bazar-international.lu)

<https://www.bazar-international.lu/>

What is the Bazar?

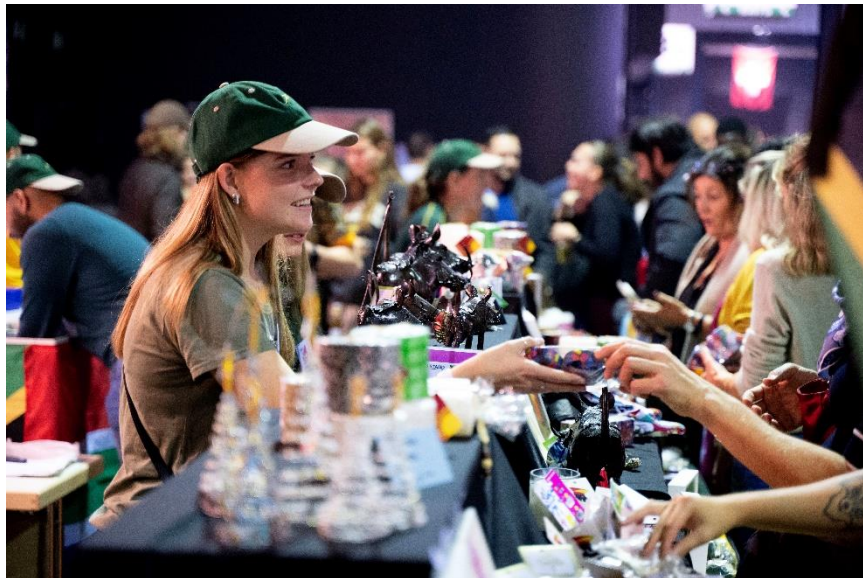

The Bazar International de Luxembourg is the largest international and annual fundraising event in Luxembourg of which the profits are donated to humanitarian projects in all corners of the world.

The three-day event is a super fun, multicultural feast for the senses and attracts thousands of visitors to the halls of LuxExpo The Box each year.

The Bazar is essentially ‘Shopping for a cause’, because all our profits are donated to wonderful and life-changing humanitarian projects around the world.

Visiting 60 countries in one day

The Bazar is made up of around 60 stands, each representing a country, or, in some cases, a group of countries. These countries, each with their own beautifully decorated stand, sell foods, drinks and a myriad of non-food items, like arts, jewellery, clothing, bags, Christmas decorations, etc. that are typical for their country.

Our visitors come to experience cultural highlights by tasting new flavours that tickle their taste buds, having exotic drinks with friends, buying great gifts and enjoying music- and dance performances from all over the world.

Individual stands’ events

Many of our stands organise events during the year to raise more money for charity and more awareness for the Bazar. Some stands have pre-sales, focusing on seasonal fashion, other stands organise concerts, one stand organises an annual pub quiz, another a yearly flower bulb sale and yet another a karting competition.

While all these smaller events are very diverse in nature, what they have in common is that they are organised for the Bazar and that their profits are donated to the charities that are handpicked by the Bazar.

To keep track of these events, please follow our socials for the latest information.

What is a stand?



The Bazar is made up of around 60 stands, most of them representing a country. During our three-day event, these stands sell products that are typical for their country. From food and drinks to a wide variety of non-food products, like jewellery, arts, clothes, accessories, toys, books and much more.

Decide if the following statements are true or false.

Tick the respective boxes. If there is not enough information in the text, tick?

	True	False	?
1. After the summer holiday, the people who organize the Bazar International have plenty of time to organize the event which takes place at the end of November.	<input type="checkbox"/>	<input type="checkbox"/>	<input type="checkbox"/>
2. They let the public know what they are doing via social media.	<input type="checkbox"/>	<input type="checkbox"/>	<input type="checkbox"/>
3. The Bazar International takes place at a weekend, that is on a Saturday and a Sunday.	<input type="checkbox"/>	<input type="checkbox"/>	<input type="checkbox"/>
4. Visitors of the Bazar International can win trips round the world.	<input type="checkbox"/>	<input type="checkbox"/>	<input type="checkbox"/>
5. The goal of the Bazar is to raise money for Luxembourg charities.	<input type="checkbox"/>	<input type="checkbox"/>	<input type="checkbox"/>
6. More or less 60 nationalities are represented at the Bazar International.	<input type="checkbox"/>	<input type="checkbox"/>	<input type="checkbox"/>
7. The Bazar weekend is an opportunity for people to eat, drink and shop as well as to attend concerts and dance performances.	<input type="checkbox"/>	<input type="checkbox"/>	<input type="checkbox"/>
8. The Bazar weekend is the only occasion when money is raised for the various charities that are supported.	<input type="checkbox"/>	<input type="checkbox"/>	<input type="checkbox"/>
9. Every stand must sell food and non-food products.	<input type="checkbox"/>	<input type="checkbox"/>	<input type="checkbox"/>
10. Every stand at the Bazar weekend represents one specific country.	<input type="checkbox"/>	<input type="checkbox"/>	<input type="checkbox"/>

There are a lot of photos from the Bazar International on the following pages. Talk about them with a partner.

Remember:

You use the present continuous tense in English to refer to images.

What is more, you say 'in the picture / in the photo'

Describe the pictures to your partner and answer the questions.

What does the following picture reveal about the event?



Who are the people in the pictures below?

What does their presence reveal about the event?



Who are the characters in the pictures below?

What does their presence reveal about the event?



There are a lot of stands which are related to specific countries.

Can you identify any of these countries? What are the typical handicrafts or foods?

What do you know about these countries?

What goods are on offer on the stands representing these countries?

What do the people on the stands look like? What are they wearing?





Not all stands are related to specific countries. Describe the following pictures.

What kind of stands can you see?

What are the people in the pictures doing?



1. Neklosdag

WHEN CHILDREN BEHAVE AT THEIR BEST³

On 6 December, all the children throughout the Grand Duchy of Luxembourg eagerly await the arrival of the Kleeschen (St Nicholas) and the gifts he brings. Unfortunately, his companion the Houseker is always by his side, carrying a big bag from which he may pull a present or a twig (= kind of stick).



The Kleeschen and the Houseker

In Luxembourg, the Kleeschen takes the form of an old man with white hair and a white beard, dressed in red. Unlike Father Christmas, St Nicholas wears a red bishop's mitre on his head and carries a bishop's crosier, a sort of staff.

He is usually accompanied by the Houseker (similar to the concept of Black Peter), his fear-inspiring dark companion, who gives twigs to children who have misbehaved.

In the Grand Duchy, this day is so important that the Ministry of National Education has decided to declare it a holiday for children in fundamental education. During the run-up to 6 December, the Kleeschen visits classes and entire schools, bringing great joy to children.

From the end of November, children leave their slippers outside their bedroom doors every night for the Kleeschen to first bring them sweets and then, during the night between 5 and 6 December, proper presents (toys and treats). In general, he does not allow himself to be seen by small children, who discover all their gifts early in the morning.

Find words or expressions in the text which mean

1. all over

2. enthusiastically

3. scary

4. to be naughty

5. time just before an event

6. real

7. Look at the picture. What is a 'mitre'?

8. What is a 'crosier'?

³ <https://luxembourg.public.lu/en/society-and-culture/festivals-and-traditions/kleeschen.html>

EVENTS & TRADITIONS - DECEMBER - KLEESCHEN!⁴

A BIT LIKE SANTA, BUT EARLIER

RTL|Update: 28.04.2021 15:19



*Léiwe Kleeschen, gudde Kleeschen
Bréng eis Saachen, allerhand
Fir ze kucken, fir ze schmaachen
Aus dem schéinen Himmelsland.*

If you want to listen to the song, go to
[https://www.youtube.com/watch?v=iVaty
KK_dSA](https://www.youtube.com/watch?v=iVatyKK_dSA)

If you've lived in Luxembourg for a while, you'll know the song. If you're new, you might be a bit confused. Is this an early Christmas celebration?

Let's get the obvious question out of the way: Is Kleeschen Santa Claus?

Not exactly! Kleeschen refers to the figure Saint Nicholas of Myra. 6 December is St Nicholas' Day and is celebrated in several countries - including all Benelux countries, parts of France, and parts of Germany. In the Netherlands, the figure is referred to as Sinterklaas (the Luxembourgish equivalent for this is Zinniklos, but most people call him Kleeschen).

Sinterklaas is actually a primary source of inspiration for the North American Santa Claus figure that we know around the globe today, but Luxembourgers predominantly focus on their own Kleeschen.

So how do Luxembourgers celebrate Kleeschen?

Tradition dictates that Kleeschen would go through villages and ask if the kids had behaved themselves during the year. If yes, he would put presents in their shoes/plates/whatever they put out by the door, but if not...his companion Houseker would give them a stick!

There is a build up to Kleeschen. In the week/two weeks before Kleeschen (at your discretion as a parent), kids lay their shoes out in a row. If they behaved themselves, they'll wake up the next morning to find chocolate or some other treat in their shoes. If they didn't behave themselves, they may find a stick courtesy of Kleeschen's companion, Houseker. The amount of sticks depends on the severity of the child's misbehaviour. On the one hand, it's a fun and exciting build-up to the festive season, but on the other hand a great way for parents to urge their kids to behave.

[Fun anecdote: My parents moved to Luxembourg when my sister was very young. Unaware of Kleeschen and its traditions, my parents did not set out any chocolates or the like in my sister's shoes. One day, she came home

⁴ <https://today.rtl.lu/luxembourg-insider/events-and-traditions/a/1628349.html>

from school and tearfully asked whether Kleeschen disliked her, as she hadn't received anything in her shoes. My parents were understandably confused and asked the neighbours what she was referring to. And then of course made up an excuse, saying that Kleeschen got lost!]

Kleeschen comes either the evening of the 5th or day of the 6th. As a child in public primary school, Kleeschen is an extra exciting day: You get the day off school! Sadly, the same doesn't apply for secondary schools, although those in their final year tend to celebrate the day regardless. Some secondary schools have had to implement strict measures for Kleeschen due to final years getting a bit ... raucous. Let's just say, there have been many occasions where Samu (emergency services) have had to make a trip to various Luxembourgish secondary schools.

Okay, I guess it's time to stock up on sticks. Are there any official celebrations as well?

Indeed. Many municipalities organise their own Kleeschen processions near the date of 6 December. Usually, Kleeschen goes to the local school and kids queue up for a treat. Luxembourgish supermarkets (i.e. Cactus, Cora, Delhaize,...) also organise their own Kleeschen events ahead of the holiday, in which kids can queue up to get a "Tiitchen", which is a bag filled with treats. Of course, there's no such thing as a free lunch (or bag of sweets), and kids usually have to sing the Kleeschen song, which you can listen to above.

If you don't speak Luxembourgish, you can find a nifty translation of the song at

<http://www.learnluxembourgish.com/blog/2013/12/5/my-favourite-kleeschen-song>).

Always good to know what you're singing.

Do shops sell any specific seasonal goodies for Kleeschen?

Yes indeed! Shops sell the chocolate figurines of St Nicholas wrapped in foil.

Tell me more about this Houseker guy. Is he like Zwarte Piet?

Houseker fulfils the same function as Zwarte Piet, but does not exactly look the same. Houseker is meant to be the same intimidating companion who gives children sticks if they misbehave. Usually dressed in black robes, Houseker has a large bushy beard and, often, his face is painted black.

AFP describes Zwarte Piet as "usually performed by an adult with a blacked-up face, wearing an afro wig, earrings, gaudy costume and red lips -- a costume that has increasingly come under fire for being a racist stereotype."

The two figures are not identical, particularly as in legend, Zwarte Piet is an African slave freed by Kleeschen. According to the Luxembourgish historian Alain Atten, Houseker's name originates from the Peasants' War of 1798 (Klëppelkrich), when the peasants had their headquarters in Housen. This means Houseker was a man from Housen who supported the peasants in the war. Indeed, Houseker's apparel is reminiscent of that of a peasant at the time.

There isn't much more specific information as to the origins of Houseker, but the black face is still problematic. Is the character blacking up to mimic the skin colour of someone black? Or, is it, as others suggest, soot? The Luxembourgish case is a bit more ambiguous than the Dutch one, but the idea of having a "bogyman" dressed up as a black person is one that causes some discomfort. However, it isn't the purpose of this article to debate the topic - it's just a part of the Kleeschen tradition that is worth being aware of. If the figure isn't rooted in racial dynamics, I think it would be easier to just forego the black face paint and allow the beard and cloak to depict the character.

Compare

	Santa Claus	Kleeschen
Origins		
Function		
Outfit		
Date when he is being celebrated		

What is often associated with a chubby, old, white-haired man?

	Zwarte Piet	Houseker
Origins		
Function		
Outfit		

What is 'blackfacing'?

What problem is with the 'Zwarte Piet'?

How would the author solve this problem with regards to the 'Houseker'?

5. It's 'Liichtmëssdag' in Luxembourg⁵

Children across Grand Duchy carry lanterns and sing in return for treats

02/02/2019

Don't forget to stock up on sweets this Saturday, as it is the traditional Luxembourg 'Liichtmëssdag'.



Traditionally, children across the Grand Duchy will set out with lanterns on 2 February, singing the 'Léiwer Herrgottsblieschen' song, wishing people in their neighbourhood good luck for the coming year. In the song, children ask for ham and peas in return for good health for the upcoming year. Ham and peas, however, have long been replaced with chocolate and sweets.

The tradition is for children to make lanterns, usually at school, and then accompanied by a few parents or teachers. However, supermarkets also sell sticks with battery-operated lights to which you can attach your paper lantern.

The tradition has Celtic roots, when farmers would carry torches across their fields, asking the goddess of fertility for a plentiful harvest. Moreover, the tradition coincided with Candlemas, the day when according to Jewish traditions, the Virgin Mary presented Jesus at the temple. Jesus is referred to as the light of the world. Also, according to some sources, monks carrying candles went out to meet them.

Whatever its origin, Liichtmëssdag remains an important date in the Luxembourg calendar.



If you plan on taking part in the tradition, police advise parents to accompany their children to ensure their safety. Children going 'liichten' should wear reflectors for better visibility, use the pavement and watch out for traffic. Motorists, too, are urged to pay attention and keep their eyes open for groups of children out on the day.

Listen to 'Léiwer Hërgottsblieschen'

https://www.youtube.com/results?search_query=Leiw+hergottsblieschen

Read the text and answer the questions. Use your own words.

1. What is going on on 2nd February?

2. Where do the children get their lanterns from?

3. What roots does 'Liichtmëssdag' have?

4. What advice does the police give to parents whose children want to take part in the tradition?

⁵ <https://www.luxtimes.lu/expathub/whats happening/it-s-liichtmessdag-in-luxembourg/1307106.html> and <https://www.luxtimes.lu/expathub/luxembourgguide/eventsandtraditions/liichtmessdag-brings-light-to-luxembourg/1356947.htm>

6. 'Buergsonndeg'

Read the texts about 'Buergbrennen'. Then answer the questions.



CORPS DES SAPEURS-POMPIERS VOLONTAIRES
COMMUNE DE PÉTANGE

BUERGBRENNEN

SONNDEG, DEN 18. FEBRUAR 2018
AM CENTRE DE LOISIRS ZU LA MADELAINE AB 14H

FIR ANIMATIOUN
Iessen
& GEDRÉNKS
ASS BESCHTENS
GESUERGT

um 19.15 Auer Faakelzuch vum
Centre de Loisirs bei d'Kraitz
um Routsis
Faakelen gëtt et op
der Plaz ze kaafen

WWW.CISP.LU

'Buergbrennen' is an age-old pagan tradition. On the first Sunday in Lent (= the 40-day period of fasting observed by many Christians in preparation for Easter), that is exactly one week after carnival Sunday, huge crosses and wooden castles are set alight all across Luxembourg. Thousands of people flock to witness the traditional lent celebration each year and preparations often already start soon after New Year's.

Local youth organisations are usually in charge of building the pyres. They obtain the materials they need from local residents and businesses.

By the way, the word 'Buerg' in 'Buergbrennen' has nothing to do with the Luxembourgish word for castle but can be traced back to the Latin word 'burere', which means burn. The fires, which represent rebirth, mark the end of winter, and are meant to melt away the snow of the old year and announce the coming of a new season.

In some towns, the main event is preceded by a torchlight procession from the centre of the village to the location of the pyre. The celebrations usually start in the afternoon or early in the evening. Usually, the pyre is lit at nightfall under the watchful eyes of the local fire department. There is no occasion like *Buergbrennen* to get to know people in the community and experience Luxembourgish cuisine as *Ierzebulli* (pea soup), *Bouneschlupp* (bean soup) and grilled sausages, are typically served on this occasion.

BUERGBRENNEN

Fête des brandons

SAMSDHES
29.02.2020
ab 14:00 Auer
Däichwisen

Traditionellen
Ierzebulli
gratis

Iessen
& Gedrénks
op gewier

Brennen
vum der Bourg
19:00 Auer

Programme:
Middes (24.02.20) bis Frelde (28.02.20)
Couture à guez (18:00)

Samschdes (29.02.20) ab 14:00 Auer
Däichwisen
Couture à guez (18:00)

19:00 Auer (Couture à guez) 19:00 Auer

Communauté d'habitants de Sion
Sion - Pöschel

BUERGBRENNEN

Samschdes
9. März 2019

18:30h Mass
dono Faakelzuch
(+ 19:30h)
C.A.S. Terrain
Schéffleng

www.sgs.lu

BUERGBRENNEN

SONNDEG,
den 18. Februar 2018

Beim **POMPJEESBAU**
op der **Gousselerstrooss**

Traditionellen
Ierzebulli

Ganzen Dag
Iessen a Gedrénks!

D' Buerg gëtt um
20:00 gebrannt!

BUERGPARTY!
Samsdes, den
17. Februar!





The men in the pictures are getting ready for 'Buegbrennen'. They are erecting a huge wooden castle, which will be set alight to drive away the winter and ring in spring.

They are bringing tons of building materials to the site with tractors and trailers. The building materials basically consist of anything that can catch fire such as pallets, branches, tree trunks, straw and old Christmas trees.

To start off with, they are setting up fifteen-metre-tall tree trunks with a digger.



Then they are cutting up the pallets with power saws so as to obtain wooden planks. They are assembling the tree trunks and the planks. Then they are filling the hollow parts of the castle with straw, branches and dried-up Christmas trees.

They are climbing up and down the structure and they are using ropes and climbing equipment to make sure they are safe.

They are also using ropes together with pulleys to lift the building materials to where they need them. Building a *Bueg* is hard work, but they are having fun.



Compare and explain the use of tenses in the two texts.

7. Bretzelsonndeg'

THE WAY TO A HEART IS THROUGH THE STOMACH

A delightful pastry

Pretzels are a Luxembourg specialty, made of puff pastry with fondant icing and almonds, representing two lovers arm in arm. Although pretzels were originally savoury (= salted), the sweet version is more common nowadays.



The capital has actually reintroduced a big parade for the event. Featuring a Pretzel Queen, the parade goes through the city centre, distributing huge amounts of delicious pastries. Of course, as opposed to being a proof of love, this event is first and foremost an efficient advertising stunt of which bakers take advantage.

Bretzelsonndeg (Pretzel Sunday)

Pretzel Sunday, or "Bretzelsonndeg" as locals call it, is a celebration of love taking place on the 4th Sunday of Lent (= fasting period). Traditionally, a man should offer a pretzel (a sweet puff pastry with fondant icing and almonds) to his sweetheart as a token of his love. If the woman reciprocates the feelings, she will in return offer him an egg on Easter day. In the unfortunate event that she is not interested, the man will be given an empty basket, hence the Luxembourgish expression *De Kuerf kréien* (= to be given the basket). In leap years, the roles are reversed: women have to offer their sweetheart a pretzel while men have to pick between an egg or a basket.

What do Luxembourg's residents think about Bretzelsonndeg? Are people still aware of the story behind the pastry?

The general consensus among the younger generation seems to be that, while nearly everybody loves to eat the sweet delight, only very few know the original custom and even fewer would consider following it. According to 17-year-old Mara, "it would be kind of weird to buy someone my age a pretzel. It's not like Valentine's Day when it's normal to buy someone a rose. At my school for example, final year students always sell roses on that occasion but I've never seen them sell pretzels."

Lexis

Find words and expressions in the text which mean

1. not sweet

2. very large, enormous

3. sign, proof

4. strange, bizarre

Find more adjectives to refer to taste as well as to the quality of food.



8. 'Klibberen'⁶

RATTLES INSTEAD OF BELLS

Why is Maundy Thursday called Gréngen Donneschdeg, i.e. "Green Thursday"? This is due to the fact that this day falls within the fasting period and that, during times in which transgressions of the abstinence commandment still met with harsh secular punishments, on this day, the day of the Last Supper according to the Bible, nothing but herb soups and green vegetables were consumed.



These days, the custom that has survived is that of children – on this day and the three subsequent ones – going 'klibberen' (roughly: going rattling, i.e. making their way through the streets bearing simple, wooden musical instruments that make a lot of noise). Legend has it that, after mass on Maundy Thursday, the church bells fly to Rome to make their Easter confession to the pope at the Vatican. To replace the bells, the children are encouraged to make lots of noise with rotary ratchets, tower rattles and wooden drums, three times a day to announce the church services.

As a reward for their deafening dedication as bell replacements, on their last round the boys called Klibberjongen – who in recent years also include an increasing number of girls – receive Easter eggs in many and various forms, confectionery and, preferably, some loose change. To express their thanks, they then all break into: "Dick dick daack, haut ass Ouschterdag...'" (dik-dik-dak, today is Easter...).

Tradition comes from social distancing

The tradition apparently gives a nod to an earlier era of social distancing. In the Middle Ages, lepers dressed in black with wide-brimmed hats would walk through the streets carrying a long wooden stick in one outstretched arm, to make sure citizens kept a healthy distance from them. In the other hand they held a "Siechenklappen" or "Klibberen" (rattle) to announce their arrival. R



⁶ Adapted from <https://luxembourg.public.lu/dam-assets/publications/a-propos-des-fetes-et-traditions-au-luxembourg/a-propos-des-fetes-et-traditions-au-luxembourg-en.pdf> and <https://www.luxtimes.lu/en/luxembourg-guide/klibberen-and-emaichen-explained-602d6f29de135b9236b98d36>

Match the words from the text (1-14) with the definitions on the right (a-n).

- | | |
|----------------------------|---|
| 1. abstinence | a. the bottom part of a hat |
| 2. confectionery | b. eating no food for a period of time |
| 3. confession | c. the fact or act of making someone suffer because they have done something wrong |
| 4. deafening | d. having a part that moves around in a circle |
| 5. era | e. not having any connection with religion |
| 6. fasting | f. an occasion when a Christian tells a priest formally and privately, what they have done wrong so that they can be forgiven |
| 7. punishment | g. a period of time of which particular events or stages of development are typical |
| 8. rotary | h. the practice of keeping away from other people as much as possible, or of keeping a certain distance from other people, in order to stop a disease from spreading to a lot of people |
| 9. secular | i. the practice of not allowing yourself something, especially food, alcoholic drinks or sex, for moral, religious or health reasons |
| 10. social distancing | j. happening or coming after something else |
| 11. subsequent | k. the act or process of breaking a law or moral rule |
| 12. transgression | l. sweets, chocolate, etc. |
| 13. brim
⇒ wide-brimmed | m. very loud, so loud it could damage one's hearing |

Write your answers here	1.	2.	3.	4.	5.	6.	7.	8.	9.	10.	11.	12.	13.

Read the text and repeat the information from the text in your own words. Find below some pictures to help you.

1.		2.	
3.		4.	
5.			

9. 'Émaischen' – Eastermarkets and pottery⁷



Péckvillcher

This tradition began in the 19th century, with the oldest written source that refers to it dating back to 1827. Émaischen is thought to be named after the biblical town of Emmaus, where Christ met two apostles after his resurrection.

A mass for the potter's brotherhood was celebrated in St Micheal's Church every Easter Monday, and at the church exit the potters sold little bird whistles known as *Péckvillchen* (singular/ *Péckvillcher plural*). The modern terracotta versions are specifically made in the village of Nospelt where you'll find the red clay often synonymous with the whistles.

Often ornately decorated, a *Péckvillche* was traditionally made by a potter at the end of the day, to make use of any left-over clay. However, the tradition was said to have died out before the First World War. It was resurrected in 1937 by Jean Peters, a ceramic artist from Reckenthal, who made the whistles from Nospelt clay.

Normally, you'll find an Easter Sunday *Péckvillchen* market in Nospelt and one in Luxembourg City at rue Marché-aux-Poissons (where the St Michel's market was moved to in the 19th century). The market is often accompanied by folk dance displays.

Originally exchanged between lovers, today the little clay wonders are considered collectors' items.

The traditional Émaischen market will return this year and, you can purchase your *Péckvillchen* at Nospelt on 18 April. There'll be concerts from Nojemer Musék and Los Figaros, plus music from DJ Relo. The Aulebäckermusée (old pottery now a museum displaying *Péckvillchen* will be open, and there will be a clown and face painting for children on Easter Monday 18 April. There'll be music from The Daredevils on 17 April.

You can also buy *Péckvillchen* in the city on Easter Monday at Marché-aux-poissons.

Watch a short video of the festival in Nospelt in 2017

[balade au Luxembourg, le 72 : Emaischen Nospelt 2017 marché aux Pickvillercher - YouTube](https://www.youtube.com/watch?v=Q9Jgjf3bf68&t=4s)
or <https://www.youtube.com/watch?v=Q9Jgjf3bf68&t=4s>

What are the three different types of pottery or ceramics?

1. Earthenware



Earthenware is often glazed with bright glossy primary colours. Red terracotta is one of the most distinctive earthenware clays. It is more porous and less strong than stoneware.

2. Stoneware



Often rustic-looking ceramics with glazes which tend to look more natural. It is generally strong, durable and non-porous which makes it a great choice for dinnerware.

3. Porcelain



Strong, non-porous and refined, porcelain can be shaped into delicate shapes to the point of being translucent. Porcelain is usually made with a white clay. Porcelain is great for dinnerware.

⁷ <https://www.luxtimes.lu/en/luxembourg-guide/klibberen-and-emaichen-explained-602d6f29de135b9236b98d36>

pottery⁸

Introduction

Pottery is the art of making containers, sculptures and other objects of clay. The clay is shaped and then fired, or baked at a high temperature, to harden it. The items created in this way are also called pottery.

Ancient peoples all around the world made pottery. Pottery was a useful invention because it could carry water or store food. Yet it also became a form of art and a way to tell stories through its paintings. Archaeologists study ancient pottery because it provides clues as to how people lived, what they believed in, how they fought and what they ate.

Types of pottery

There are three basic types of pottery – earthenware, stoneware and porcelain. Earthenware is also called clayware. It is the simplest and oldest form of pottery. Stoneware is a denser type of pottery. Porcelain is a smooth, white type of pottery.

Earthenware is porous, which means that water can soak through it, even after it is fired. But when earthenware is coated with a substance called a glaze, liquid cannot soak through.

Liquid cannot soak through stoneware and porcelain even when they are left unglazed. If a glaze is applied, it is only for decoration. Stoneware is very hard. Porcelain is usually light, thin and translucent, meaning that light can shine through it. Both stoneware and porcelain originated in China more than 1,000 years ago. Many people still call porcelain 'china'.



Porcelain vase from the reign of the Jiajing Emperor (1521–1567)

How pottery is made

Before pottery is made, the clay must be cleaned. Any dirt or small rocks must be removed. Then, if the clay has dried, the potter mixes it with water until it can be easily shaped.

The simplest way to make pottery is to start by making long ropes of clay. The potter then coils the strands on top of each other to make a bowl or vase shape. Finally, the potter smooths the coils to make an even surface.

Another method of making pottery is called slip casting. The potter pours liquid clay into molds where it hardens. Slip casting is useful for making pottery in flat or unusual shapes.

One of the most popular ways to make pottery is with a potter's wheel. The potter first puts a chunk of clay on the wheel, which is a round, flat surface that spins around. The potter then shapes the spinning mass of clay into a pot. Because the wheel spins, it is easy for the potter to keep the sides of the pot even. The wheel is most useful for making rounded shapes.

Once the pottery is shaped, it is prepared for firing. The pottery must be completely dried. It will dry slowly in the air, but today many potters use automatic dryers to speed up the process. Sometimes the potter carves the pottery before it is fired. Using a blade, the potter can thin a pot's walls or create decorations.

When the pottery is ready to be fired, the potter places it in a kiln, or high-temperature oven. The temperature needed depends on the type of pottery and its decoration. Earthenware may need a temperature of 760° C (1,400° F). Stoneware or porcelain may need a much higher temperature of 1,480° C (2,700° F).

After firing, the hardened pottery can be glazed and painted. Glazes are made of ground minerals that produce different colours. Iron oxide (green), ferric oxide (yellow), copper (red) and cobalt (blue) are some common glaze ingredients. Other materials used in glazes include feldspar, quartz, silica and boric acid. Depending on the type of pottery, paint may be applied either under or over the glaze. After glazing and painting, the pottery is often fired again so that the glaze hardens and becomes shiny.

⁸ <https://kids.britannica.com/kids/article/pottery/399569>

10. The 'Meekranz' and the 1st May⁹

Most people know that 1 May is Labour Day, and since 1889 it's been a day off for workers in Luxembourg, and a time for them to reiterate their demands on pay and rights, as well as to celebrate. The trade unions normally organise a festival at Neimenster Abbey cultural centre which brings live jazz, rock and blues to the place. There are kids theatre performances, workshops, and a magic illusion show, as well as a gastronomy village.



Buxus or box tree bush

longer observed, in the past, young men would plant a tree in the garden of a sweetheart, or townsfolk would plant a tree in front of the mayor's house to show they thought that he was doing a good job.

Nowadays some people merely head into the forest on 1 May to collect branches with fresh leaves and weave them into 'Meekränz' (May wreaths). Very often the trip to collect the branches is a communal event organised by the scouts or a local sporting or music club. The branches are then woven together into a circular wreath to be hung on the premises of a club or the front door of a café.



Lily of the Valley

However, there have been numerous May customs in and around Luxembourg long before Labour Day. These customs are often based on heathen sacrificial feasts, which have been incorporated into the Christian calendar subsequently.

er. They would also mark their front door and those of barns and stables with a chalk cross.

Another local May tradition is the erection of a 'Meebam' or May tree. Although it is no



'Meekranz'

In France it's a tradition to give Lily of the Valley on 1 May, and you'll find them in the shops in Luxembourg too. This dates back to the Renaissance when Charles IX is thought to have offered these lilies to the ladies of the court on 1 May. Germany celebrates 30 April and 1 May with Walpurgisnacht – in honour of Saint Walpurga who was hailed by German Christians for battling pestilence, rabies, whooping cough and witchcraft. In western Luxembourg and Arlon, after making your wreath, you return home to take a sip of 'Maitrank' – a concoction of white wine and sweet woodruff (also known as baby's breath or Waldmeister).

Read the text and decide if the sentences below are true or false and tick the respective box. If there is not enough information in the recording, tick '?'.

	True	False	?
1. Labour Day is the most recent of the different May traditions.	<input type="checkbox"/>	<input type="checkbox"/>	<input type="checkbox"/>
2. A lot of May traditions have their origins in pre-Christian times.	<input type="checkbox"/>	<input type="checkbox"/>	<input type="checkbox"/>
3. 'Meebeem' are not actual trees that are being planted somewhere, but poles that are being put up in certain places.	<input type="checkbox"/>	<input type="checkbox"/>	<input type="checkbox"/>
4. Meekränz are wreaths made of fresh branches and beautiful flowers.	<input type="checkbox"/>	<input type="checkbox"/>	<input type="checkbox"/>
5. King Charles IX offered Lilies of the Valley to all the single ladies he wanted to date.	<input type="checkbox"/>	<input type="checkbox"/>	<input type="checkbox"/>
6. Saint Walpurga is a famous witch.	<input type="checkbox"/>	<input type="checkbox"/>	<input type="checkbox"/>
7. 'Maitrank' is a mixed drink.	<input type="checkbox"/>	<input type="checkbox"/>	<input type="checkbox"/>

⁹ Adapted from [Meekranz and Oktav | Luxembourg Times \(luxtimes.lu\)](https://www.luxtimes.lu)

11. 'Oktav'¹⁰



Our Lady, Mary, Comforter of the Afflicted Photo: Anouk Antony

The Oktav is Luxembourg's most significant religious celebration. The Oktav is a pilgrimage in honour of Our Lady of Luxembourg, the Virgin Mary. It begins every year on the 3rd Sunday after Easter and finishes with a procession on the 5th Sunday after Easter. The name Octav originates from a time when the worship of the Virgin Mary lasted only eight days. Nowadays it is two weeks, but the name has remained unchanged.

The origins of the Oktav lie in the war and pestilence that raged in the region in the 17th century, in other words the 30 Years War (1618-1648), and a 10-year plague (1626-1636), which led to a famine and the death of two-thirds of the population. Initially Jesuit students carried a wooden statue of the Virgin Mary to a chapel in Glacis. She was given the title 'Our Lady, Mary, Comforter of the Afflicted'. She became the patron saint of the city in 1666 and the patron saint for the whole of the country in 1678. Pilgrims would travel from all over Luxembourg and the greater region (the Eifel region of Germany, Lorraine in France and Belgium) to the city to attend an Oktav mass and ask for the afflictions to come to an end. Following this, they'd have a slap-up (= particularly large and good) meal and get a bit of shopping done at the 'Oktavmäertchen'.

The 'Oktavmäertchen', literally small market, which was initially organised to ensure pilgrims had somewhere to eat and drink after church as well as purchase one or the other souvenir, has developed into a highlight of the celebrations. It is a kind of fair on Place Guillaume II with a handful of restaurants selling fried fish, stalls selling other kinds of food and crafts and even a few fairground rides. It is a great opportunity for believers, as well as non-believers to come together.



During the Oktav, the statue of Our Lady is decorated and dressed, and displayed on a special altar inside the cathedral for pilgrims to give thanks and prayer to. The end of the Oktav is marked by a ceremonial final procession, in which a statue of Mary is carried through the streets of the capital. The Grand Ducal family also participates in this tradition along with members of the government and other dignitaries.

Watch a short video on the Oktav

https://www.youtube.com/watch?v=qgat_gimHI0

Grammar

Find the two sentences which contain the auxiliary 'would' in the text.

What is this verb form called (= what verbal mood is it)?

What does this verb form express?

¹⁰ Adapted from [Luxembourg's 'Oktav', what is it and how is it celebrated? \(luxtimes.lu\)](https://www.luxtimes.lu/expathub/luxembourgguide/eventsandtraditions/meekranz-and-oktav/1323371.html)
<https://www.luxtimes.lu/expathub/luxembourgguide/eventsandtraditions/meekranz-and-oktav/1323371.html> g

Lexis

Match the verbs from the text (1-6) with their definitions (a-f). There is an example (0,o).

- | | | |
|--|--|---|
| <p>0. altar</p> <p>1. chapel</p> <p>2. mass</p> <p>3. patron saint</p> <p>4. pilgrim</p> <p>5. prayer</p> <p>6. procession</p> <p>7. worship</p> | | <p>a. a Christian saint who is believed to protect a particular place or group of people</p> <p>o. holy table in a church or temple</p> <p>b. to have or show a strong feeling of respect and admiration for God or a god</p> <p>c. a line of people or vehicles that move along slowly, especially as part of a religious or public ceremony</p> <p>d. a person who makes a journey, often a long and difficult one, to a special place for religious reasons</p> <p>e. a religious ceremony in some Christian churches based on Jesus' last meal with his disciples</p> <p>g. a small church or an enclosed place in a large church for worship by a small group, or a room in a building set apart for worship</p> <p>g. words that you say to God giving thanks or asking for help</p> |
|--|--|---|

Write your answers here

0.	1	2	3	4	5	6	7
o							

Find words and expressions in the text which match the following definitions (0-5). There is an example (0)

- | | |
|---|---|
| <p>0. an amount of something that can be held in one hand</p> <p>1. the best, most interesting or most exciting part of something</p> <p>2. a disease spread by rats that causes a high temperature, swellings on the body and usually death in humans</p> <p>3. any disease that spreads quickly and kills a lot of people</p> <p>4. to go officially and usually regularly to a place</p> <p>5. a situation in which there is not enough food for a great number of people, causing illness and death</p> | <p><i>handful</i></p> <hr/> <hr/> <hr/> <hr/> <hr/> |
|---|---|

Comprehension

Read the text and decide if the sentences below are true or false and tick the respective box..

- | | | | | | | | | | | | | | | | | | | | | | | |
|---|--|--------------------------|--------------|----------|--------------------------|--------------------------|--------------------------|--------------------------|--------------------------|--------------------------|--------------------------|--------------------------|--------------------------|--------------------------|--------------------------|--------------------------|--------------------------|--------------------------|--------------------------|--------------------------|--------------------------|--------------------------|
| <p>If there is not enough information in the recording, tick ' ?'</p> <p>1. The Oktav is a pilgrimage.</p> <p>2. The Oktav goes on for eight days.</p> <p>3. In the 17th century people ask the Virgin Mary to protect them against the war, the plague and the resulting famine.</p> <p>4. The Virgin Mary is the patron saint of Luxembourg, Belgium, the Eifel and the Lorraine.</p> <p>5. The pilgrims travel to Luxembourg city first and foremost to go shopping.</p> <p>6. Only catholic Christians are allowed to enjoy the 'Oktavmäertchen'.</p> <p>7. The Grand Ducal family and members of the government carry a statue of the Virgin Mary through the streets of the capital city.</p> | <table border="0"> <tr> <td style="text-align: right;">True</td> <td style="text-align: right;">False</td> <td style="text-align: right;">?</td> </tr> <tr> <td style="text-align: right;"><input type="checkbox"/></td> <td style="text-align: right;"><input type="checkbox"/></td> <td style="text-align: right;"><input type="checkbox"/></td> </tr> <tr> <td style="text-align: right;"><input type="checkbox"/></td> <td style="text-align: right;"><input type="checkbox"/></td> <td style="text-align: right;"><input type="checkbox"/></td> </tr> <tr> <td style="text-align: right;"><input type="checkbox"/></td> <td style="text-align: right;"><input type="checkbox"/></td> <td style="text-align: right;"><input type="checkbox"/></td> </tr> <tr> <td style="text-align: right;"><input type="checkbox"/></td> <td style="text-align: right;"><input type="checkbox"/></td> <td style="text-align: right;"><input type="checkbox"/></td> </tr> <tr> <td style="text-align: right;"><input type="checkbox"/></td> <td style="text-align: right;"><input type="checkbox"/></td> <td style="text-align: right;"><input type="checkbox"/></td> </tr> <tr> <td style="text-align: right;"><input type="checkbox"/></td> <td style="text-align: right;"><input type="checkbox"/></td> <td style="text-align: right;"><input type="checkbox"/></td> </tr> </table> | True | False | ? | <input type="checkbox"/> | <input type="checkbox"/> | <input type="checkbox"/> | <input type="checkbox"/> | <input type="checkbox"/> | <input type="checkbox"/> | <input type="checkbox"/> | <input type="checkbox"/> | <input type="checkbox"/> | <input type="checkbox"/> | <input type="checkbox"/> | <input type="checkbox"/> | <input type="checkbox"/> | <input type="checkbox"/> | <input type="checkbox"/> | <input type="checkbox"/> | <input type="checkbox"/> | <input type="checkbox"/> |
| True | False | ? | | | | | | | | | | | | | | | | | | | | |
| <input type="checkbox"/> | <input type="checkbox"/> | <input type="checkbox"/> | | | | | | | | | | | | | | | | | | | | |
| <input type="checkbox"/> | <input type="checkbox"/> | <input type="checkbox"/> | | | | | | | | | | | | | | | | | | | | |
| <input type="checkbox"/> | <input type="checkbox"/> | <input type="checkbox"/> | | | | | | | | | | | | | | | | | | | | |
| <input type="checkbox"/> | <input type="checkbox"/> | <input type="checkbox"/> | | | | | | | | | | | | | | | | | | | | |
| <input type="checkbox"/> | <input type="checkbox"/> | <input type="checkbox"/> | | | | | | | | | | | | | | | | | | | | |
| <input type="checkbox"/> | <input type="checkbox"/> | <input type="checkbox"/> | | | | | | | | | | | | | | | | | | | | |

12. 'Sprangprëssessioun'¹¹

ECHTERNACH HOPPING PROCESSION - RECOGNISED BY UNESCO, ATTRACTING THOUSANDS OF VISITORS EACH YEAR.



On Whit Tuesday each year, the ancient abbey town of Echternach hosts the hopping procession, which is called the 'Sprangprëssessioun' in Luxembourgish. This local tradition attracts thousands of pilgrims every year from across the Grand Duchy and neighbouring countries to celebrate the cult of Saint Willibrord.

A pilgrimage with its own special tune

Early in the morning, the first pilgrims gather in the shadow of the main courtyard of the former abbey of Echternach. They meet to take part in a truly unique event. Both, participants and spectators, come to pay homage to Saint Willibrord, an Anglo-Saxon Benedictine monk, revered as the founder of Echternach Abbey and honoured for his gift of curing illness.

Those who take part in the hopping procession skip through the streets of the city and use the whole body to enter into prayer. The pilgrims celebrate the cult of St. Willibrord by walking but mainly by hopping to the rhythm of musical bands.

Before the start of the 'Sprangprëssessioun', a mass is celebrated in the basilica. At the end of mass, the Archbishop of Luxembourg issues a greeting to those in attendance and then the dancers, lined up in rows of five to six people, take their positions. Dressed in white and black or blue, they all hold a white handkerchief in their hand. They advance through the town, while making small hopping movements to the rhythm of a 'Sprangprëssessioun' melody: one step to the left, one step to the right.

With these simple steps, the pilgrims, accompanied by municipal ensembles and brass bands which play the same melody, hop through the streets of the abbey town. At the end of the procession, which in general lasts about an hour, the dancers and spectators gather together at the basilica. According to the tradition, they parade one by one past the tomb of Saint Willibrord. A thanksgiving service brings the event to a close.

For the people of Echternach in particular, proper dress is required: blue trousers or skirt with a white top.

© Communication and press department of the Catholic Church in Luxembourg

An event with international appeal

Each year, this famous procession attracts about 10,000 pilgrims and spectators from Luxembourg and neighbouring countries such as France, Belgium, Germany and even the Netherlands to celebrate this religious festival which has become a cultural phenomenon over the years. Since the end of the 15th century, this completely unique event has made Echternach world-famous and since 2010 the 'Sprangprëssessioun' has been included in UNESCO's Intangible Heritage of Humanity.

Watch a short video on the Hopping Procession

<https://www.youtube.com/watch?v=4nehqiAWFGY>

¹¹ [Echternach Hopping Procession - Luxembourg \(public.lu\)](https://public.lu)

Lexis

Match the words from the text (1-6) with their definitions (a-f). There is an example (0,o).

0. abbey

1. archbishop

2. basilica

3. courtyard

4. monk

5. service

6. tomb

a. an area of flat ground outside that is partly or completely surrounded by walls of a building

b. a bishop of the highest rank who is in charge of churches and other bishops in a particular large area

o. a building where monks and nuns live or used to live

c. a formal religious ceremony

d. a large stone structure or underground room where someone, especially an important person, is buried

e. a member of a group of religious men who live apart from other people in a monastery and who do not marry or have personal possessions

f. a large church or hall with a curved end and two rows of columns supporting the roof inside

Write your answers here

0.	1	2	3	4	5	6
o						

Find words and expressions in the text which match the following definitions (0-18). There is an example (0)

0. deep respect and often praise shown for a person or god

1. to make someone with an illness healthy again

2. to make something finish

3. of or in an earlier time, before the present time or in the past

4. to move by doing small jumps on one foot or two feet

5. to move forwards lightly and quickly making a little jump with each step

6. to provide the space and other things necessary for a special event

7. a small piece of material or paper used for cleaning the nose, or drying the eyes, etc.

Comprehension

Read the text and decide if the sentences below are true or false and tick the respective box..

If there is not enough information in the recording, tick '?'

	True	False	?
1. Saint Willibrord came from the British Isles.	<input type="checkbox"/>	<input type="checkbox"/>	<input type="checkbox"/>
2. The participants of the procession skip to the rhythm of different tunes.	<input type="checkbox"/>	<input type="checkbox"/>	<input type="checkbox"/>
3. The Archbishop of Luxembourg heads the procession.	<input type="checkbox"/>	<input type="checkbox"/>	<input type="checkbox"/>
4. The different events in Echternach go on for about an hour.	<input type="checkbox"/>	<input type="checkbox"/>	<input type="checkbox"/>
5. Participants in the procession are supposed to observe a specific dress code.	<input type="checkbox"/>	<input type="checkbox"/>	<input type="checkbox"/>
6. On Whit Tuesday there are about 10,000 pilgrims hopping through the streets of Echternach.	<input type="checkbox"/>	<input type="checkbox"/>	<input type="checkbox"/>

13. 'Nationalfeierdag'¹²

NATIONAL DAY - WHEN THE WHOLE OF LUXEMBOURG CELEBRATES THE GRAND DUKE'S BIRTHDAY

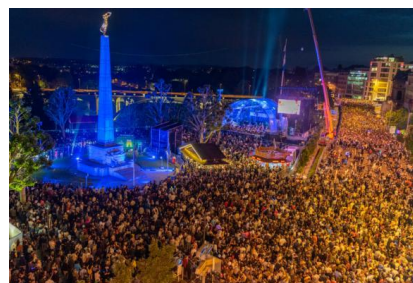

It's National Day in Luxembourg! It's a great opportunity for everyone to gather for the festivities organised across the entire country on 22nd and 23rd June. This day of celebration is firmly anchored in Luxembourgers' minds and it provides a perfect opportunity to enjoy two days of concerts, fireworks, games for children and commemorative ceremonies.

Popular festivals all over the place

The ceremonies usually get under way at 4 p.m. on 22nd June with the traditional changing of the guard in front of the Grand Ducal Palace, with the participation of an honorary detachment from the Luxembourg Army. Musical accompaniment will be provided by the Luxembourg Military Band. The show will really be worth your while! It is also an opportunity to meet members of the Grand Ducal families: while the Grand Ducal couple visit a different town in Luxembourg each year, the Grand Duke's heir, accompanied by his wife, always visits the country's second largest city, Esch-sur-Alzette.

Torchlight procession and fireworks

The eve of Luxembourg's National Day is above all a time for festivities. A large number of popular events are organised across the entire country. The programme is so loaded that wherever you are, you can be sure that you will be among the festivities, whether you are a resident or a tourist. A highlight of the evening is certainly the Fakelzuch, the torchlight procession. It is made up of national and local associations, walking bands and folk groups parading through Luxembourg City. To the rhythm of Luxembourg walking bands and music bands of foreign communities in Luxembourg, the groups parade before the Grand Duke Henri and the Grand Duchess Maria Teresa. But the evening's stunning finale takes place at dusk, at 11 p.m., as the sky bursts into flame with a spectacular firework display. A long-awaited moment by thousands of people each year!

Ceremonies, parade and events

The programme for National Day starts on 23 June at 10 a.m. with an official ceremony at the Luxembourg Philharmonie. The Grand Ducal family attends it, just as deputies, as do government officials and the general public. It is first and foremost an occasion for the Grand Duke, the Prime Minister and the President of the Chamber of Deputies to address the country as a whole, but it also features high points such as when honours are awarded to deserving Luxembourgers. It goes without saying that the Philharmonie goes hand in hand with concert halls. In fact, the official ceremony ends with music played by the Luxembourg Philharmonic Orchestra. Each year, the honour of creating this musical work goes to a different composer. The ceremony in the Philharmonie is followed by the traditional 21-gun salute fired in the Grand Duke's honour. The ceremonial drill and the military parade are always a magnet for crowds along the boulevard where troops will march. The parade brings together representatives of the army, police, customs, Grand Ducal Fire and Rescue Corps, prison administration, Red Cross and music bands of the Grand Duke Adolphe Union. Luxembourg military planes fly over the parade at low altitude. The official programme ends with the traditional Te Deum in the late afternoon at Notre-Dame de Luxembourg Cathedral, in the presence of members of the Grand Ducal family.

Animation for everybody

On top of the official ceremonies, there is the traditional Spillfest (games event) in the park in Luxembourg City on the Kinnekswiss, a large green area amidst the Municipal Park in Luxembourg City, which is a raging success. This event - which takes place from 10 a.m. to 6 p.m. - provides an opportunity to discover some unusual educational games offered by a number of associations and national and international performers. Attendance is free of charge and there will of course be stands with snacks and drinks. For fans of military vehicles and uniforms, the army organises its Arméifest (army festival) on Place des martyrs square, better known under its Luxembourgish name: Rousegäertchen (rose garden). There, the army displays military vehicles and systems and you can enjoy a friendly drink. This marks the end of the two days when Luxembourg's society and all its communities participate in order to show the country's unity.

© SIP / Charles Caratini

Last update 22.06.2022

¹² <https://luxembourg.public.lu/en/society-and-culture/festivals-and-traditions/national-day.html>

Comprehension

Complete the table and say when the following events in the box take place

- | | |
|---|---|
| <ul style="list-style-type: none"> ▪ Arméifest ▪ Changing of the guard ▪ Fireworks ▪ Honours awarded to deserving Luxembourgers ▪ Military parade ▪ Music by the Luxembourg Military band ▪ Music by the Luxembourg Philharmonic Orchestra | <ul style="list-style-type: none"> ▪ Music by Luxembourg walking bands and music bands of foreign communities in Luxembourg ▪ Speeches by the Grand Duke, the Prime Minister and the President of the Chamber of Deputies ▪ Service at Notre-Dame de Luxembourg Cathedral ▪ 'Spillfest' ▪ Torchlight procession ▪ Twenty-one gun salute |
|---|---|

DATE	TIME	MAIN EVENT	PROGRAMME POINTS WHICH ARE PART OF THE EVENT
22/06	4pm	Changing of the Guard	Changing of the Guard Music by the Luxembourg Military band
23/06			

14. 'Summer in the City'¹³

Read the following article announcing a series of events in Luxembourg City. It referred to the future at the time of its publication and study the use of tenses.

About Summer in the City

The Luxembourg City Tourist Office is pleased to announce the 'Summer in the City 2022' programme which takes place from 17 June to 12 September 2022.

As in the previous 26 editions, the 'Summer in the City 2022' programme includes leisure activities, music, exhibitions, theatre, shopping and many other cultural and tourist activities, all taking place in Luxembourg City.

The event labelled 'Summer in the City' is the result of a good collaboration between the different actors of the capital, institutional partners, such as the City of Luxembourg.

Comprehension

What is the name of the event? _____

When does the event take place? _____

Which tense is used for the verb used to publish the date of the event? Why? _____

Is the event a one-off occasion? _____

What does the event consist of? _____

Who organises the event? _____

Which tenses are used in the text? _____

¹³ <https://www.luxembourg-city.com/en/summer-in-the-city>

15. Schueberfouer¹⁴

From Wikipedia, the free encyclopedia



Schueberfouer funfair in Luxembourg, 2013

The Schueberfouer is the annual Luxembourg City funfair held on the Glacis square in the city district of Limpertsberg. The 680th edition of the largest amusement park in the wider region beyond national borders will start on 20 August 2021 and ends on 8 September 2021.

Traditionally, the Schueberfouer starts on Wednesday, Thursday or Friday before Saint Bartholomew's day (24 August) and closes on Monday, Tuesday or Wednesday before 12 September in order to last 20 days every year. In 2010, the fair comprised 184 attractions including 27 major

rides, 13 children's rides and 54 restaurants and snacks bars. In 2018, the fair was expected to attract over 2 million visitors.

History

John I of Luxembourg, better known as John the Blind, King of Bohemia and Count of Luxembourg, founded the Schueberfouer on 20 October 1340.

The founding document stated: It will begin on the eve of the feast of St Bartholomew and will last for a full eight days.

Even today, it remains linked to St Bartholomew's day, 24 August, the traditional opening date.

The name Schueberfouer is thought to originate probably from the name of the marketplace where it was first held: the Schuedbuerg, today's "Plateau du St Esprit" (in English: Holy Spirit Plateau; in Luxembourgish: Helleggeesch-Plateau), which serves nowadays as residential location for the highest courts of justice of Luxembourg. ("Fouer" is the Luxembourgish word for "fair".)

Another unconfirmed theory links the term "Schueber" to the old German word "Schober" (in English: barn), which would refer to the initial agricultural role of the fair. Indeed, for almost 450 years, the fair was mainly a large and regionally very important market for everything from agricultural products and livestock to cloth, pottery and other household items.

After the Limpertsberg wood had been removed to improve the defensive capabilities of the city, the fair moved in 1610 to the Glacis, a huge open space beyond the westward fortifications of Luxembourg City which were destroyed after 1867 and replaced by the City Park.

During the 18th century, shows and games became part of the fair but it was not until the early 20th century that a Ferris wheel and a rollercoaster first appeared.



The Ferris Wheel

¹⁴ <https://en.wikipedia.org/wiki/Schueberfouer>

Attractions at the 'Schueberfouer'

Use the words in the box to identify the rides and the food in the pictures. Then find the words in the word search.

- | | | | |
|-----------------|--------------|---------------------|---------------|
| Belgian waffles | drop tower | 'Gromperkichelcher' | swing ride |
| bumper cars | ferris wheel | merry-go-round | toffee apples |
| candy floss | fried fish | rollercoaster | |
| catch the duck | ghost train | shooting gallery | |



Word search grid:

```

V S L R D R C B L G D R
W S S D D E J E E H N O
Y O E T L H A L E O U L
R L L Y P C D G H S O L
E F P A U L R I W T R E
L Y P X M E O A S T O R
L D A M H H P N I R G C
A N E O H C T W R A Y O
G A E H Z I O A R I R A
G C F M O K W F E N R S
N Z F R V E E F F B E T
I X O W I R R L B K M E
T M T S G E X E K H F R
O Q B L W P D S L X W F
O E H Y H M I F U W M R
H N X M J O X X I H Z Z
S W I N G R I D E S L D
Q T Y I I G Y J F D H O
C A T C H T H E D U C K
S R A C R E P M U B C P
    
```

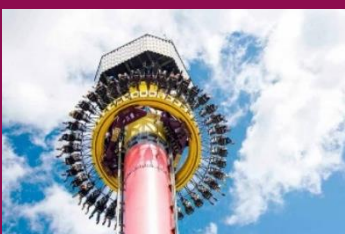

16. Kirmes¹⁵

THE ORIGINS OF THE LUXEMBOURGISH KIRMES

Author: Dani Lodhi-Dunne | Update: 26.07.2021 10:00

While the Schueberfouer is the country's largest 'Kirmes', it's not the only one.

What are the origins of the Kirmes?

A traditional kirmes, or kermesse, is a parish festival. The word comes from the Dutch "kerk" (church) and "mis" mass, and originally celebrated the anniversary of the church. Such celebrations were popular across the Benelux countries, northern France and Central Europe.

Originally, the fairs involved good food, company, dancing and music, as well as competitions, with livestock as the prize. While they were almost exclusively religious fairs in Belgium, for example, a Kirmes in Germany was more likely to be aimed at adults, with a strong alcoholic presence. Nowadays, they are more likely to feature fairground rides, sweet treats and games, as focus has shifted from religious meaning to fun and enjoyment. Children now frequently return home from the Kirmes with a cuddly toy won in a game, rather than a sheep or a goose won in a competition. In France, a Kirmes is usually held at the end of the academic year at a school, with tombolas and other stalls to raise funds.

Where can I find them?

Anywhere, really! Some towns hold a Kirmes at Easter, such as Esch-sur-Alzette. Others hold them throughout the year, usually to coincide with religious festivals. If you're a resident of Luxembourg City, you can find a list here; otherwise, check with your local municipality as chances are your local area will have one at some point!

What is there to do at a Kirmes?

Eat, drink and be merry! Nowadays many Kirmes' have games and rides, such as bumper cars, tombola style games and the ever-popular duck fishing game. You can find many of the Grand Duchy's stalwart foods, such as sausages, 'Gromperkichelchen' and the classic churros, although some may have more localised treats.



La Kermesse by Peter Paul Rubens

What's the Schueberfouer then? Is it a Kirmes?

Some large funfairs, such as the Schueberfouer, Brussels' Foire du Midi or Antwerps' Sinksenfoor, first began life as a Kirmes and later evolved into the visitor attractions in their current form. But don't take my word for it, read the history of the Schueberfouer here.

Why is there a brass band playing outside my house?

A traditional Luxembourgish folk tune- the so-called Hämmelesmarsch - is associated with a Kirmes and is usually played by local brass bands as they walk through the streets. Ostensibly this was meant to invite people to the village fair.

Once upon a time the musicians were accompanied by sheep, but this particular tradition appears to have died out, although it lives on in the name (Hämmel is the Luxembourgish word for a wether, or a castrated ram). Chances are if you've lived in Luxembourg long enough, you've been roused by the familiar thumping (= here: loud) melody on a weekend morning more than once...

Above all, the Kirmes is designed to spread good humour across a local community.

The Kirmes tradition has spread across the world, with some communities of Dutch, Belgian and Luxembourgish descent in the US, Canada and Latin America holding Kirmes events in order to raise funds for charities. In Luxembourg, they are a demonstration of how a cultural tradition has evolved to suit modern society's tastes, retaining their appeal across centuries.

¹⁵ [RTL Today - Year round - Kirmes: The origins of the Luxembourgish Kirmes](https://today.rtl.lu/luxembourg-insider/events-and-traditions/a/1628338.html)
<https://today.rtl.lu/luxembourg-insider/events-and-traditions/a/1628338.html>

Lexis

Match the verbs from the text (1-6) with their definitions (a-f). There is an example (0,o).

0. to coincide

1. to evolve

2. to involve

3. to rouse

4. to spread

5. to suit

6. to retain

a. to happen at or near the same time

b. to develop gradually, especially from a simple to a more complicated form

c. if a situation, an event or an activity involves something, that thing is an important and necessary part or result of it

d. to wake someone up or make someone more active or excited

e. to cause something to reach a wider area

f. to be convenient or useful for somebody

o. to happen at or near the same time

Write your answers here

0	1	2	3	4	5	6
o						

Find words and expressions in the text which match the following definitions (0-12). There is an example (0)

0. a band (= group of musicians) in which most of the instruments, are made of brass, i.e. a bright yellow metal made by mixing copper and zinc

brass band

1. a location with its own local government, or the local government itself

2. a male sheep

3. a quality that makes somebody or something attractive or interesting

4. a toy animal that is covered in fur and that is soft

5. a series of musical notes that are sung or played in a particular order to form a piece of music, especially one that is pleasant and easy to remember

6. a short journey in a vehicle, on a bicycle, etc.

7. a table or small shop with an open front that people sell things from, especially at a market

8. a type of entertainment in a field or park at which people can ride on large machines and play games to win prizes

9. an area that has its own church and that a priest is responsible for

10. the animals kept on a farm, for example cows or sheep

11. help, especially in the form of money, given freely to people who are in need

12. something very pleasant that somebody can enjoy, especially something that you give somebody or do for them

13. according to what seems or is stated to be real or true, when it is perhaps not the case

14. of the present time

Listen to 'Den Hämmelsmarsch' and 'Et ass Kirmes am Duerf', two traditional pieces of music, played at a Kirmes.

[Hämmelsmarsch 2020 - YouTube](https://www.youtube.com/watch?v=0J2vtzJlriA)
<https://www.youtube.com/watch?v=0J2vtzJlriA>

